

## VYVRTÁVACIE HLAVY STAVITEĽNÉ



PANAS Tools s.r.o., Hradište 371, 958 54 Hradište-SK  
info@panas.sk, www.panas.sk

# 1.02

## VYVRTÁVACÍ HLAVY SE ZVÝŠENOU PŘESNOSTÍ – Vh PRECISION BORING HEADS – Vh CABEZALES ALESADORES DE ALTA PRECISIÓN – Vh

česky  
english  
español



Vyvrtačací hlavy se zvýšenou přesností slouží k přesnému vyvrtávání válcových otvorů v uvedeném rozsahu průměrů. Jejich zvýšená přesnost při seřizování vyvrtávaného průměru vychází z použití diferenciálního pohybového šroubu a pomocné kruhové matice. Ta je buď šroubem unášena a otáčí se s ním – poloha „I“ pro hrubé nastavování a nebo s ním zabírá – poloha „II“ pro jemné nastavování rozměru. V tomto případě je matice zabrzdněna dotažením šroubu pos. 10. Hlavy se dodávají se základním příslušenstvím v dřevěné kazetě. Upínací stopka je vyměnitelná a není součástí příslušenství. Proto je třeba ji objednávat zvlášť.

Precision boring heads are used for precision boring of cylindrical holes in the given range of diameters. Their accuracy of the boring diameter adjustment proceeds from the differential screw and subsidiary round nut. This nut is either carried by the screw and then they rotate together – Position I – for the coarse adjustment, or this nut screws on the screw – Position II for the fine adjustment. In this case, the nut is braked by tightening the screw no. 10. Boring heads are delivered with primary accessories in wooden boxes. The taper shank is exchangeable and it is not included in the primary accessories. The taper shank has to be ordered as a special item.

Este tipo de cabezales sirve para alesar con precisión los orificios cilíndricos dentro de la escala de diámetros indicada. El aumento de precisión al ajustar el diámetro elegido está dado por el tornillo diferencial móvil y la tuerca circular auxiliar. Hay dos opciones: la tuerca es arrastrada por el tornillo y gira junto con él - I. posición para el ajuste previo, o labra junto con él - II. posición para el ajuste de diámetro fino. En este caso la tuerca se frena si el tornillo se aprieta, posición 10.

Los cabezales se suministran junto con los accesorios básicos en un estuche de madera. La espiga de sujeción se puede cambiar y no forma parte del accesorio, por lo tanto hay que solicitarla en un pedido especial.

PŘESNOST NASTAVOVÁNÍ – ADJUSTING ACCURACY – PRECISIÓN DE AJUSTE

	I. 1 DIV = 0,02 mm/∅	Vh 70
	II. 1 DIV = 0,0025 mm/∅	Vh 110
		Vh 140

### TECHNICKÁ DATA – TECHNICAL DATA – PARÁMETROS TÉCNICOS

	Kód Code Código	Rozsah Range Escala		DH7 [mm]	A <sub>1</sub> [mm]	B [mm]	L [mm]		
Vh 70	205.014	6 – 105 (130)*	VK360	16	70	62	82	2,0	3,6
Vh 110	205.021	15 – 165 (300)*	VK801	25	110	84	100	4,6	9,0
Vh 140	205.038	15 – 225 (400)*	VK801	25	140	82	104	6,3	11,2

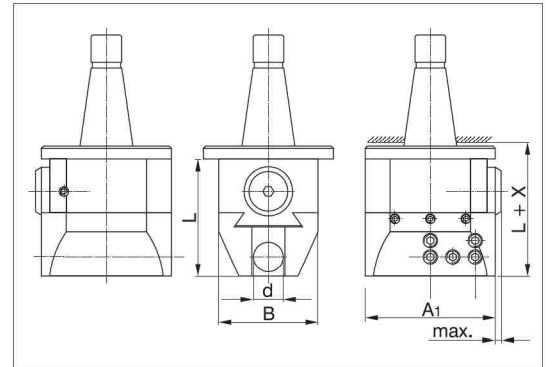
### PŘÍSLUŠENSTVÍ Vh A Vhs – ACCESSORIES Vh AND Vhs – ACCESORIOS Vh Y Vhs

	NŮŽ – TOOL – CUCHILLA				NŮŽ – TOOL – CUCHILLA				NŮŽ – TOOL – CUCHILLA				NŮŽ – TOOL – CUCHILLA			
	221710 <b>1</b>				221711 <b>2</b>				HSS <b>3</b>				S20 (S30) <b>4</b>			
	d × D × L	n	kód-code-código	d × D × L	n	kód-code-código	a × a × L	n	kód-code-código	a × a × L	n	kód-code-código	a × a × L	n	kód-code-código	
Vh 70	5 × 10 × 60	1	411172101306	5 × 10 × 60	1	411172111306										
	13 × 16 × 90	1	411172104409	13 × 16 × 90	1	411172114409										
Vh 110	13 × 16 × 90	1	411172104409	13 × 16 × 90	1	411172114409										
Vh 140	13 × 16 × 90	1	411172104409	13 × 16 × 90	1	411172114409										
Vhs 50	6 × 12 × 70	1	4111721046127	6 × 12 × 70	1	4111721146127										
Vhs 10 – 125	13 × 16 × 90	1	411172104409	13 × 16 × 90	1	411172114409	8 × 8 × 40	2	412926047500	8 × 8 × 30	2	415249324821				
							20 × 20 × 80	1	412926047700							
Vhs 40 – 180							10 × 10 × 36	2	412926050200	10 × 10 × 36	2	415249324921				
										25 × 25 × 100	1	411434111406				

\* s použitím držáku – with a holder application – con empleo de portaherramientas

PANAS Tools s.r.o., Hradište 371, 958 54 Hradište-SK, info@panas.sk, www.panas.sk



## VYVRTÁVACÍ HLAVY STAVITELNÉ – Vhs ADJUSTABLE BORING HEADS – Vhs CABEZALES ALESADORES AJUSTABLES – Vhs



Vyvrtačací hlavy stavitelné se používají k přesnému vyvrtačení válcových otvorů na vyvrtačích nebo i jiných obráběcích strojích. Upínací stopka je vyměnitelná – není součástí tělesa hlavy. Upínací otvory v saních jsou kruhové nebo kombinované pro upnutí kruhového a čtyřhranného profilu těla nože. Hlavy se dodávají s příslušenstvím ve dřevěných kazetách. Pracovní rozsah hlavy je udán v jejich označení (Vhs 5 – 50:  $d_{min.} = 5 \text{ mm}$ ,  $d_{max.} = 50 \text{ mm}$ ).

Adjustable boring heads are used for precision boring of cylindrical holes on boring machines or on the other machine tools. The taper shank is exchangeable – it is not a constituent part of the body. The clamping holes in the slide are round or combined for clamping of the round or square section of shanks. These heads are delivered with accessories in wooden boxes. The working range of the head is given in their marking (Vhs 5 – 50:  $d_{min.} = 5 \text{ mm}$ ,  $d_{max.} = 50 \text{ mm}$ ).

Este tipo de cabezales se emplea para alesar con precisión los orificios cilíndricos en las alesadoras u otras máquinas herramienta.

La espiga de sujeción se puede cambiar – no forma parte del cuerpo del cabezal. Los agujeros de sujeción en las guías son circulares o combinados para sujetar el cuerpo de cuchilla de perfil circular o cuadrangular. Los cabezales se suministran junto con los accesorios en un estuche de madera. Alcance de acción del cabezal viene en su indicación (Vhs 5–50:  $d_{min.} = 5 \text{ mm}$  y  $d_{max.} = 50 \text{ mm}$ ).

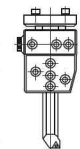

česky  
english  
español

### PŘESNOST NASTAVOVÁNÍ – ADJUSTING ACCURACY – PRECISIÓN DE AJUSTE

	1 DIV = 0,01 mm/∅	Vhs 50 Vhs 10 – 125
	1 DIV = 0,02 mm/∅	Vhs 40 – 180

### TECHNICKÁ DATA – TECHNICAL DATA – PARÁMETROS TÉCNICOS

	Kód Code Código	Kužel Cone Cono	d [mm]	DH7 A H11 [mm]	a [mm]	b [mm]	L [mm]		
Vhs 50	204.208	VK360	∅ 70	D=∅12	∅ 50	∅ 50	75	1,5	2,0
Vhs 10 - 125	204.185	VK360	∅ 70	D=∅25 A=20	79	60	103	3,0	4,1
Vhs 40 - 180	204.192	VK801	∅ 110	D=∅32 A=25	102	76	138	6,5	10,5

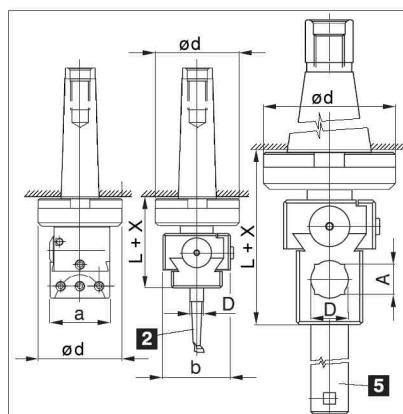

### VYVRTÁVACÍ TYČ – BORING BAR – BARRA PARA ALESAR

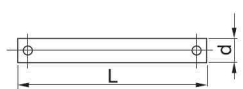

5

### DRŽÁK – HOLDER – PORTAHERRAMIENTAS

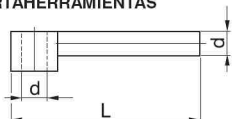

6

### REDUKČNÍ POUZDRO – REDUCTION – CASQUILLO DE REDUCCIÓN

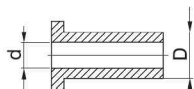

7

### KLIČ – WRENCH – LLAVE

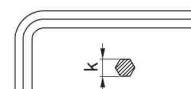

8

d × L	n	kód-code-código	d × L	n	kód-code-código	D/d	n	kód-code-código	k	n	kód-code-código
			16 × 56 /1**	1	410070112701	16/10	1	412926014300	4	1	413324000400
			16 × 56 /2**	1	410070112801	25/16	1	412926021700	6	1	413324000600
			25 × 115	1	410110111901	25/16	1	412926021700	4; 6	1	
			25 × 135	1	410140112501				4; 6	1	
									4	1	
									6	1	
25 × 160	1	412926019400				25/16	1	412926021700	4; 6	1	
32 × 250	1	412926035600							4; 6	1	

\*\* zvláštní příslušenství – special accessories – accesorio especiales

n – počet kusů – no. of pieces – no. de unidades

## VYVRTÁVACÍ HLAVY SE ZVÝŠENOU PŘESNOSTÍ – Vh FEINBOHRKÖPFE – Vh РАСТОЧНЫЕ ГОЛОВКИ ТОЧНЫЕ – Vh

česky  
deutsch  
по-русски



Vyvrťovací hlavy se zvýšenou přesností slouží k přesnému vyvrťování válcových otvorů v uvedeném rozsahu průměrů. Jejich zvýšená přesnost při seřizování vyvrťovaného průměru vychází z použití diferenciálního pohybového šroubu a pomocné kruhové matice. Ta je buď šroubem unášena a otáčí se s ním – poloha I pro hrubé nastavování a nebo s ním zabírá – poloha II pro jemné nastavování rozměru. V tomto případě je matice zabrzděna dotažením šroubu poz. 10. Hlavy se dodávají se základním příslušenstvím v dřevěné kazetě. Upínací stopka je vyměnitelná a není součástí příslušenství. Proto je třeba ji objednávat zvlášť.

Diese Ausbohrköpfe dienen zum präzisen Ausbohren der zylindrischen Bohrungen im angegebenen Durchmesserbereich. Ihr erhöhte Einstellgenauigkeit des Ausbohrdurchmessers kommt aus der Verwendung der Differentialschraube und der runden Hilfsmutter her. Diese Mutter ist entweder durch die Schraube mitgenommen und dreht sich mit - Stellung I. - für Voreinstellen oder schraubt sich ein - Stellung II. für feines Einstellen. Die Mutter ist im zweiten Fall durch das Festziehen der Schraube Nr. 10 gebremst. Die Ausbohrköpfe werden mit Grundzubehör in den Holzkassetten geliefert. Der Kegelschaft ist austauschbar und ist nicht im Grundzubehör eingeschlossen. Es ist notwendig den Kegelschaft separat zu spezifizieren und bestellen.

Расточные головки с повышенной точностью предназначаются для точного сверления цилиндрических отверстий в указанном диапазоне диаметров. Их повышенная точность при регулировке растачиваемого диаметра основана на применении дифференциального движущегося винта и вспомогательной круглой гайки. Эта гайка вращается вместе с винтом – положение I для точной установки размера. В данном случае гайка тормозится с помощью дополнительной затяжки винта поз. 10. Головки поставляются вместе с основными принадлежностями в деревянном футляре. Зажимный хвостовик взаимозаменяемый, он не входит в объем принадлежностей. Поэтому его следует заказывать отдельно.

PŘESNOST NASTAVOVÁNÍ – EINSTELLENGENAUIGKEIT – Точность настройки

	I. 1 DIV = 0,02 mm/∅	Vh 70
	II. 1 DIV = 0,0025 mm/∅	Vh 110
		Vh 140

### TECHNICKÁ DATA – TECHNISCHE DATEN – ТЕХНИЧЕСКИЕ ДАННЫЕ

	Kód Code Код	Rozsah Bereich Диапазон		DH7 [mm]	A <sub>1</sub> [mm]	B [mm]	L [mm]		
Vh 70	205.014	6 – 105 (130)*	VK360	16	70	62	82	2,0	3,6
Vh 110	205.021	15 – 165 (300)*	VK801	25	110	84	100	4,6	9,0
Vh 140	205.038	15 – 225 (400)*	VK801	25	140	82	104	6,3	11,2

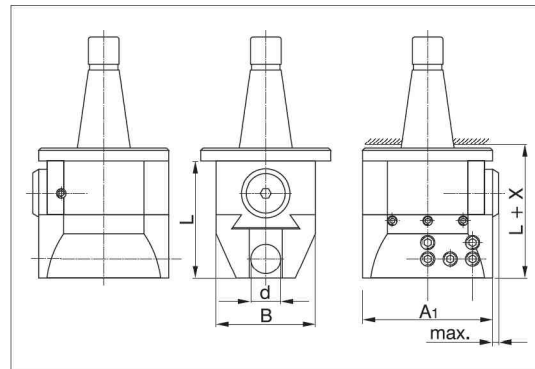
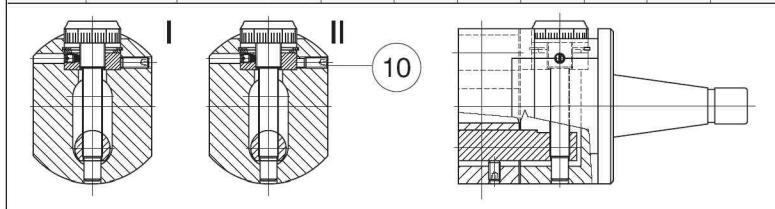

### PŘÍSLUŠENSTVÍ Vh a Vhs – ZUBEHÖR Vh UND Vhs – ПРИНАДЛЕЖНОСТИ Vh и Vhs

	NŮŽ – MEISSEL – РЕЗЕЦ				NŮŽ – MEISSEL – РЕЗЕЦ				NŮŽ – MEISSEL – РЕЗЕЦ				NŮŽ – MEISSEL – РЕЗЕЦ					
	221710 <b>1</b>				221711 <b>2</b>				HSS <b>3</b>				S20 (S30) <b>4</b>					
	d × D × L	n	kód-Code-код		d × D × L	n	kód-Code-код	a × a × L	n	kód-Code-код		a × a × L	n	kód-Code-код		a × a × L	n	kód-Code-код
Vh 70	5 × 10 × 60	1	411172101306		5 × 10 × 60	1	411172111306											
	13 × 16 × 90	1	411172104409		13 × 16 × 90	1	411172114409											
Vh 110	13 × 16 × 90	1	411172104409		13 × 16 × 90	1	411172114409											
Vh 140	13 × 16 × 90	1	411172104409		13 × 16 × 90	1	411172114409											
Vhs 50	6 × 12 × 70	1	4111721046127		6 × 12 × 70	1	4111721146127											
Vhs 10 – 125	13 × 16 × 90	1	411172104409		13 × 16 × 90	1	411172114409	8 × 8 × 40	2	412926047500		8 × 8 × 30	2	415249324821				
								20 × 20 × 80	1	412926047700								
Vhs 40 – 180								10 × 10 × 36	2	412926050200		10 × 10 × 36	2	415249324921				
												25 × 25 × 100	1	411434111406				

\* s použitím držáku – mit Halter – с применением держателя



## VYVRTÁVACÍ HLAVY STAVITELNÉ – Vhs VERSTELLBAHRE AUSBOHRKÖPFE – Vhs РАСТОЧНЫЕ ГОЛОВКИ РАЗДВИЖНЫЕ – Vhs



Vyvrtačací hlavy stavitelné se používají k přesnému vyvrtačání válcových otvorů na vyvrtačích nebo i jiných obráběcích strojích. Upínací stopka je vyměnitelná – není součástí tělesa hlavy. Upínací otvory v saních jsou kruhové nebo kombinované pro upnutí kruhového a čtyřhravého profilu těla nože. Hlavy se dodávají s příslušenstvím v dřevěných kazetách. Pracovní rozsah hlavy je udán v jejich označení (Vhs 5 – 50:  $d_{min.} = 5 \text{ mm}$ ,  $d_{max.} = 50 \text{ mm}$ ).

Diese Ausbohrköpfe dienen zum präzisen Ausbohren der zylindrischen Bohrungen an den Bohrwerken oder anderen Werkzeugmaschinen. Der Kegelschaft ist austauschbar – es ist nicht ein Bestandteil des Kopfkörpers. Die Spannbohrungen im Schlitten haben runde oder kombinierte Form für Spannen der runden oder quadratischen Meisseln. Die Köpfe werden in Holzkassetten geliefert. Der Arbeitsbereich des Kopfes ist in seiner Bezeichnung angegeben d.h. (Vhs 5 – 50:  $d_{min.} = 5 \text{ mm}$ ,  $d_{max.} = 50 \text{ mm}$ ).

Эти головки употребляются для точной расточки цилиндрических отверстий на расточных или других станках. Зажимный хвостовик заменяемый – не входит в состав корпуса головки. Зажимные отверстия в салазках круглые или комбинированные для зажима круглого или квадратного сечения резца. Головки поставляются с принадлежностями в деревянной cassette. Диапазон применения головок указан в их обозначении. (Vhs 5–50:  $d_{мин.} = 5 \text{ мм}$ ,  $d_{макс.} = 50 \text{ мм}$ ).

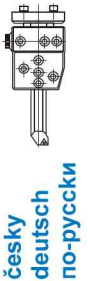

### PŘESNOST NASTAVOVÁNÍ – EINSTELLENAUIGKEIT – Точность настройки

	1 DIV = 0,01 mm/∅	Vhs 50 Vhs 10 – 125
	1 DIV = 0,02 mm/∅	Vhs 40 – 180

### TECHNICKÁ DATA – TECHNISCHE DATEN – ТЕХНИЧЕСКИЕ ДАННЫЕ

	Kód Code Код	Kužel Schaft Конус	d [mm]	DH7 A H11 [mm]	a [mm]	b [mm]	L [mm]		
Vhs 50	204.208	VK360	∅ 70	D=∅12	∅ 50	∅ 50	75	1,5	2,0
Vhs 10 - 125	204.185	VK360	∅ 70	D=∅25 A=20	79	60	103	3,0	4,1
Vhs 40 - 180	204.192	VK801	∅ 110	D=∅32 A=25	102	76	138	6,5	10,5

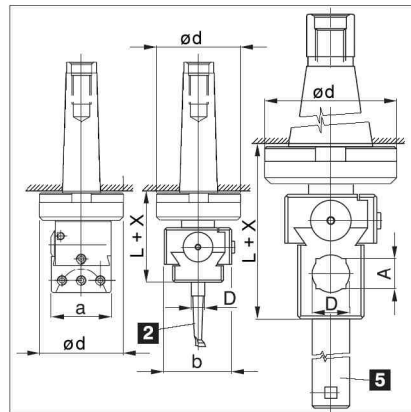

### VYVRTÁVACÍ TYČ – BOHRSTANGE – ОПРАВКА РАСТОЧНАЯ

### DRŽÁK – HALTER – ДЕРЖАТЕЛЬ

### REDUKČNÍ POUZDRO – REDUZIERHÜLSE – ВТУЛКА ПЕРЕХОДНАЯ

### KLÍČ – SCHLÜSSEL – Ключ

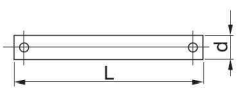

5

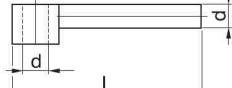

6

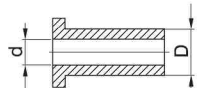

7

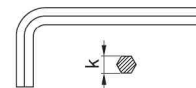

8

d x L	n	kód-Code-код	d x L	n	kód-Code-код	D/d	n	kód-Code-код	k	n	kód-Code-код
			16 x 56 / 1**	1	410070112701	16/10	1	412926014300	4	1	413324000400
			16 x 56 / 2**	1	410070112801	25/16	1	412926021700	6	1	413324000600
			25 x 115	1	410110111901	25/16	1	412926021700	4; 6	1	
			25 x 135	1	410140112501				4; 6	1	
									4	1	
									6	1	
25 x 160	1	412926019400				25/16	1	412926021700	4; 6	1	
32 x 250	1	412926035600							4; 6	1	



\*\* zvláštní příslušenství – Sonderzubehör – специальные принадлежности

n – počet kusů – Stückzahl – штук

# KUŽELOVÉ STOPKY VYMĚNITELNÉ

## EXCHANGEABLE TAPER SHANKS REPLACEABLE

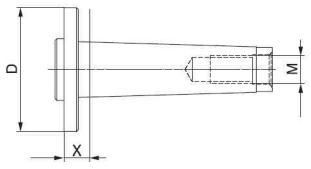
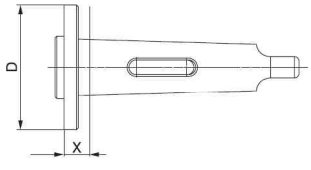
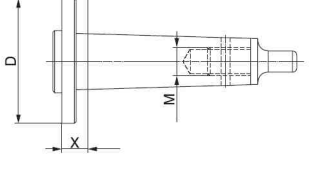
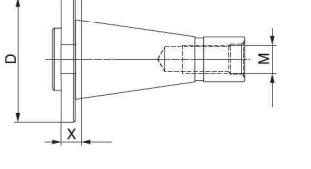
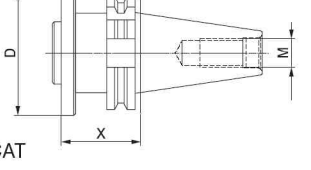
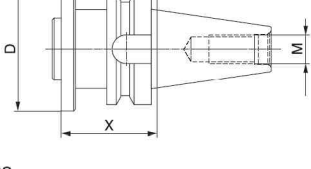
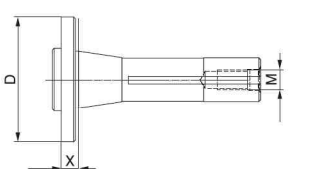
### ESPIGAS CÓNICAS REEMPLAZABLES

VK	Kód Code Código	Popis Description Descripción	V/hu 36	V/hu 56	V/hu 80	V/hu 110	V/hu 125	V/hu 160	V/h 70	V/h 110	V/h 140	V/hš 50/10/125	V/hš 40-180	D [mm]	X [mm]		Náčrt Drawing Croquis
VK 360	208.015	MK2-M8 DIN 228A	●						●					70	13	0,35	 <p>DIN 228A, ISO 296-63, ČSN 220420</p>
VK 360	208.022	MK2-M10 DIN 228A	●						●					70	13	0,35	
VK 360	208.039	MK2-3/8"-16 UNC	●						●					70	13	0,35	
VK 360	208.060	MK3-M10 DIN 228A	●						●					70	13	0,46	
VK 360	208.077	MK3-M12 DIN 228A	●						●					70	13	0,46	 <p>DIN 1806, ISO 296-63, ČSN 220424</p>
VK 360	208.084	MK3-1/2"-12 UNC	●						●					70	13	0,46	
VK 360	208.121	MK4-M14 DIN 228A	●						●					70	14,5	0,75	
VK 360	208.138	MK4-M16 DIN 228A	●						●					70	14,5	0,75	
VK 360	208.145	MK4-5/8"-11 UNC	●						●					70	14,5	0,75	 <p>SPECIAL *</p>
VK 801	208.510	MK4-M14 DIN 228A		●	●	●			●			●		110	18,5	1,35	
VK 801	208.527	MK4-M16 DIN 228A		●	●	●			●			●		110	18,5	1,35	
VK 801	208.534	MK4-5/8"-11 UNC		●	●	●			●			●		110	18,5	1,35	
VK 801	208.572	MK5-M16 DIN 228A		●	●	●	●		●	●		●		110	18,5	2,29	 <p>DIN 2080, ISO 297, ČSN 220430</p>
VK 801	208.589	MK5-M20 DIN 228A		●	●	●	●		●	●		●		110	18,5	2,29	
VK 801	208.596	MK5-3/4"-10 UNC		●	●	●	●		●	●		●		110	18,5	2,29	
VK 801	208.633	MK6-M20 DIN 228A		●	●	●	●		●	●		●		110	20	4,74	
VK 801	208.640	MK6-M24 DIN 228A		●	●	●	●		●	●		●		110	20	4,74	 <p>DIN 69871/A, ISO 297, ČSN 220434</p>
VK 801	208.664	MK6-1"-8 UNC		●	●	●	●		●	●		●		110	20	4,74	
VK 360	208.053	MK3-DIN 1806	●						●			●		70	13	0,47	
VK 360	208.114	MK4-DIN 1806	●						●			●		70	14,5	0,77	
VK 360	208.169	MK5-DIN 1806	●						●			●		70	14,5	1,5	 <p>CAT MAS - BT</p>
VK 360	208.176	MK6-DIN 1806	●						●			●		70	38	4,16	
VK 801	208.503	MK4-DIN 1806		●	●	●			●	●		●		110	18,5	1,47	
VK 801	208.565	MK5-DIN 1806		●	●	●	●		●	●		●		110	18,5	2,45	
VK 801	208.626	MK6-DIN 1806		●	●	●	●		●	●		●		110	20	4,54	 <p>R8</p>
VK 360	208.046	MK2-(3/8"-16 UNC) *	●						●			●		70	13	0,36	
VK 360	208.091	MK3-(M12) *	●						●			●		70	13	0,47	
VK 360	208.107	MK3-(1/2"-13 UNC) *	●						●			●		70	13	0,47	
VK 360	208.152	MK4-(5/8"-11 UNC) *	●						●			●		70	14,5	0,75	
VK 801	208.541	MK4-(M16) *		●	●	●			●	●		●		110	18,5	1,46	
VK 801	208.558	MK4-(5/8"-12 UNC) *		●	●	●			●	●		●		110	18,5	1,46	
VK 801	208.602	MK5-(M20) *		●	●	●	●		●	●		●		110	18,5	2,22	
VK 801	208.619	MK5-(3/4"-10 UNC) *		●	●	●	●		●	●		●		110	18,5	2,22	
VK 801	208.671	MK6-(M24) *		●	●	●	●		●	●		●		110	20	4,53	
VK 801	208.688	MK6-(1"-8 UNC) *		●	●	●	●		●	●		●		110	20	4,53	
VK 360	208.183	ISO 30 (M12) DIN 2080	●						●			●		70	9,6	0,4	
VK 360	208.190	ISO 30 (1/2"-13 UNC)	●						●			●		70	9,6	0,4	
VK 360	208.213	ISO 40 (M16) DIN 2080	●						●			●		70	9,6	0,74	
VK 360	208.220	ISO 40 (5/8"-11 UNC)	●						●			●		70	9,6	0,74	
VK 360	208.244	ISO 50 (M24) DIN 2080	●						●			●		70	45,2	3,19	
VK 801	208.695	ISO 40-(M16) DIN 2080		●	●	●	●		●	●		●		110	13,6	1,35	
VK 801	208.701	ISO 40-(5/8"-11 UNC)		●	●	●	●		●	●		●		110	13,6	1,35	
VK 801	208.725	ISO 50-(M24) DIN 2080		●	●	●	●		●	●		●		110	15,2	2,89	
VK 801	208.732	ISO 50-(1"-8 UNC)		●	●	●	●		●	●		●		110	15,2	2,89	
VK 360	208.206	ISO 30 (M12) DIN 69871/A	●						●			●		70	49,1	0,75	
VK 360	208.282	CAT 30 (1/2"-13 UNC)	●						●			●		70	44,2	0,75	
VK 360	208.237	ISO 40 (M16) DIN 69871/A	●						●			●		70	49,1	1,35	
VK 360	208.299	CAT 40 (5/8"-11 UNC)	●						●			●		70	49,1	1,35	
VK 360	208.251	ISO 50 (M24) DIN 69871/A	●						●			●		70	49,1	3,05	
VK 801	208.718	ISO 40-(M16) DIN 69871/A		●	●	●	●		●	●		●		110	48,1	1,95	
VK 801	208.770	CAT 40-(5/8"-11 UNC)		●	●	●	●		●	●		●		110	48,1	1,95	
VK 801	208.749	ISO 50-(M24) DIN 69871/A		●	●	●	●		●	●		●		110	65,1	4,78	
VK 801	208.787	CAT 50-(1"-8 UNC)		●	●	●	●		●	●		●		110	65,1	4,78	
VK 360	208.268	MAS-BT30 (M12)	●						●			●		70	34,6	0,70	
VK 360	208.275	MAS-BT40 (M16)	●						●			●		70	57,0	1,55	
VK 801	208.756	MAS-BT40 (M16)		●	●	●	●		●	●		●		110	43,6	2,12	
VK 801	208.763	MAS-BT50 (M24)		●	●	●	●		●	●		●		110	84,0	5,70	
VK 360	208.305	R8 (7/16"-20 UNF)	●						●			●		70	17,6	0,69	
VK 800	208.817	R8 (7/16"-20 UNF)		●										63	17,6	0,64	

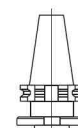





česky  
english  
español

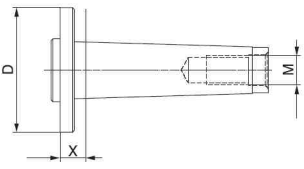
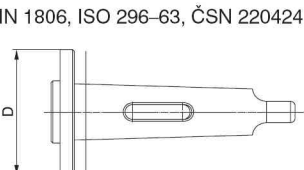
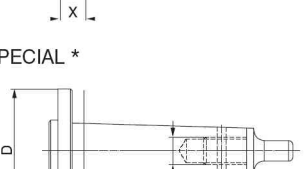

## KUŽELOVÉ STOPKY VYMĚNITELNÉ AUSTAUSCHBARE KEGELSCHÄFTE ВЗАИМОЗАМЕНЯЕМЫЕ КОНИЧЕСКИЕ ХВОСТОВИКИ

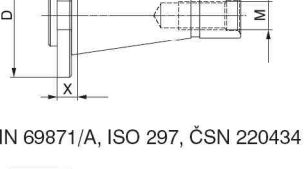
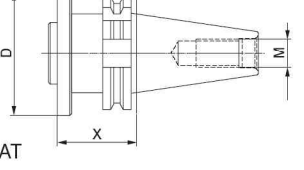
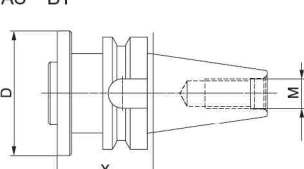
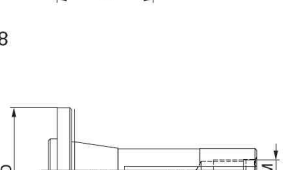
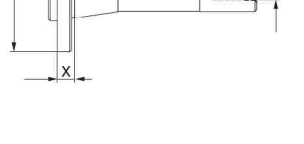
česky  
deutsch  
по-русски

VK	Kód Code Код	Popis Beschreibung Описание	Vhu 36	Vhu 56	Vhu 80	Vhu 110	Vhu 125	Vhu 160	Vh 70	Vh 110	Vh 140	Vhs 50/10-125	Vhs 40-180	D [mm]	X [mm]		Náčrt Zeichnung Эскиз
VK 360	208.015	MK2-M8 DIN 228A	●						●					70	13	0,35	
VK 360	208.022	MK2-M10 DIN 228A	●						●					70	13	0,35	
VK 360	208.039	MK2-3/8"-16 UNC	●						●					70	13	0,35	
VK 360	208.060	MK3-M10 DIN 228A	●						●					70	13	0,46	
VK 360	208.077	MK3-M12 DIN 228A	●						●					70	13	0,46	
VK 360	208.084	MK3-1/2"-12 UNC	●						●					70	13	0,46	
VK 360	208.121	MK4-M14 DIN 228A	●						●					70	14,5	0,75	
VK 360	208.138	MK4-M16 DIN 228A	●						●					70	14,5	0,75	
VK 360	208.145	MK4-5/8"-11 UNC	●						●					70	14,5	0,75	
VK 801	208.510	MK4-M14 DIN 228A		●	●	●			●	●	●	●	●	110	18,5	1,35	
VK 801	208.527	MK4-M16 DIN 228A		●	●	●			●	●	●	●	●	110	18,5	1,35	
VK 801	208.534	MK4-5/8"-11 UNC		●	●	●			●	●	●	●	●	110	18,5	1,35	
VK 801	208.572	MK5-M16 DIN 228A		●	●	●	●	●	●	●	●	●	●	110	18,5	2,29	
VK 801	208.589	MK5-M20 DIN 228A		●	●	●	●	●	●	●	●	●	●	110	18,5	2,29	
VK 801	208.596	MK5-3/4"-10 UNC		●	●	●	●	●	●	●	●	●	●	110	18,5	2,29	
VK 801	208.633	MK6-M20 DIN 228A		●	●	●	●	●	●	●	●	●	●	110	20	4,74	
VK 801	208.640	MK6-M24 DIN 228A		●	●	●	●	●	●	●	●	●	●	110	20	4,74	
VK 801	208.664	MK6-1"-8 UNC		●	●	●	●	●	●	●	●	●	●	110	20	4,74	
VK 360	208.053	MK3-DIN 1806	●						●					70	13	0,47	
VK 360	208.114	MK4-DIN 1806	●						●					70	14,5	0,77	
VK 360	208.169	MK5-DIN 1806	●						●					70	14,5	1,5	
VK 360	208.176	MK6-DIN 1806	●						●					70	38	4,16	
VK 801	208.503	MK4-DIN 1806		●	●	●			●	●	●	●	●	110	18,5	1,47	
VK 801	208.565	MK5-DIN 1806		●	●	●	●	●	●	●	●	●	●	110	18,5	2,45	
VK 801	208.626	MK6-DIN 1806		●	●	●	●	●	●	●	●	●	●	110	20	4,54	
VK 360	208.046	MK2-(3/8"-16 UNC) *	●						●					70	13	0,36	
VK 360	208.091	MK3-(M12) *	●						●					70	13	0,47	
VK 360	208.107	MK3-(1/2"-13 UNC) *	●						●					70	13	0,47	
VK 360	208.152	MK4-(5/8"-11 UNC) *	●						●					70	14,5	0,75	
VK 801	208.541	MK4-(M16) *		●	●	●			●	●	●	●	●	110	18,5	1,46	
VK 801	208.558	MK4-(5/8"-12 UNC) *		●	●	●			●	●	●	●	●	110	18,5	1,46	
VK 801	208.602	MK5-(M20) *		●	●	●	●	●	●	●	●	●	●	110	18,5	2,22	
VK 801	208.619	MK5-(3/4"-10 UNC) *		●	●	●	●	●	●	●	●	●	●	110	18,5	2,22	
VK 801	208.671	MK6-(M24) *		●	●	●	●	●	●	●	●	●	●	110	20	4,53	
VK 801	208.688	MK6-(1"-8 UNC) *		●	●	●	●	●	●	●	●	●	●	110	20	4,53	
VK 360	208.183	ISO 30 (M12) DIN 2080	●						●					70	9,6	0,4	
VK 360	208.190	ISO 30 (1/2"-13 UNC)	●						●					70	9,6	0,4	
VK 360	208.213	ISO 40 (M16) DIN 2080	●						●					70	9,6	0,74	
VK 360	208.220	ISO 40 (5/8"-11 UNC)	●						●					70	9,6	0,74	
VK 360	208.244	ISO 50 (M24) DIN 2080	●						●					70	45,2	3,19	
VK 801	208.695	ISO 40-(M16) DIN 2080		●	●	●	●	●	●	●	●	●	●	110	13,6	1,35	
VK 801	208.701	ISO 40-(5/8"-11 UNC)		●	●	●	●	●	●	●	●	●	●	110	13,6	1,35	
VK 801	208.725	ISO 50-(M24) DIN 2080		●	●	●	●	●	●	●	●	●	●	110	15,2	2,89	
VK 801	208.732	ISO 50-(1"-8 UNC)		●	●	●	●	●	●	●	●	●	●	110	15,2	2,89	
VK 360	208.206	ISO 30 (M12) DIN 69871/A	●						●					70	49,1	0,75	
VK 360	208.282	CAT 30 (1/2"-13 UNC)	●						●					70	44,2	0,75	
VK 360	208.237	ISO 40 (M16) DIN 69871/A	●						●					70	49,1	1,35	
VK 360	208.299	CAT 40 (5/8"-11 UNC)	●						●					70	49,1	1,35	
VK 360	208.251	ISO 50 (M24) DIN 69871/A	●						●					70	49,1	3,05	
VK 801	208.718	ISO 40-(M16) DIN 69871/A		●	●	●	●	●	●	●	●	●	●	110	48,1	1,95	
VK 801	208.770	CAT 40-(5/8"-11 UNC)		●	●	●	●	●	●	●	●	●	●	110	48,1	1,95	
VK 801	208.749	ISO 50-(M24) DIN 69871/A		●	●	●	●	●	●	●	●	●	●	110	65,1	4,78	
VK 801	208.787	CAT 50-(1"-8 UNC)		●	●	●	●	●	●	●	●	●	●	110	65,1	4,78	
VK 360	208.268	MAS-BT30 (M12)	●						●					70	34,6	0,70	
VK 360	208.275	MAS-BT40 (M16)	●						●					70	57,0	1,55	
VK 801	208.756	MAS-BT40 (M16)		●	●	●	●	●	●	●	●	●	●	110	43,6	2,12	
VK 801	208.763	MAS-BT50 (M24)		●	●	●	●	●	●	●	●	●	●	110	84,0	5,70	
VK 360	208.305	R8 (7/16"-20 UNF)	●						●					70	17,6	0,69	
VK 800	208.817	R8 (7/16"-20 UNF)	●						●					63	17,6	0,64	