

Vhu

VYVRTÁVACÍ NÁŘADÍ
BORING TOOLS
HERRAMIENTAS DE ALESAR

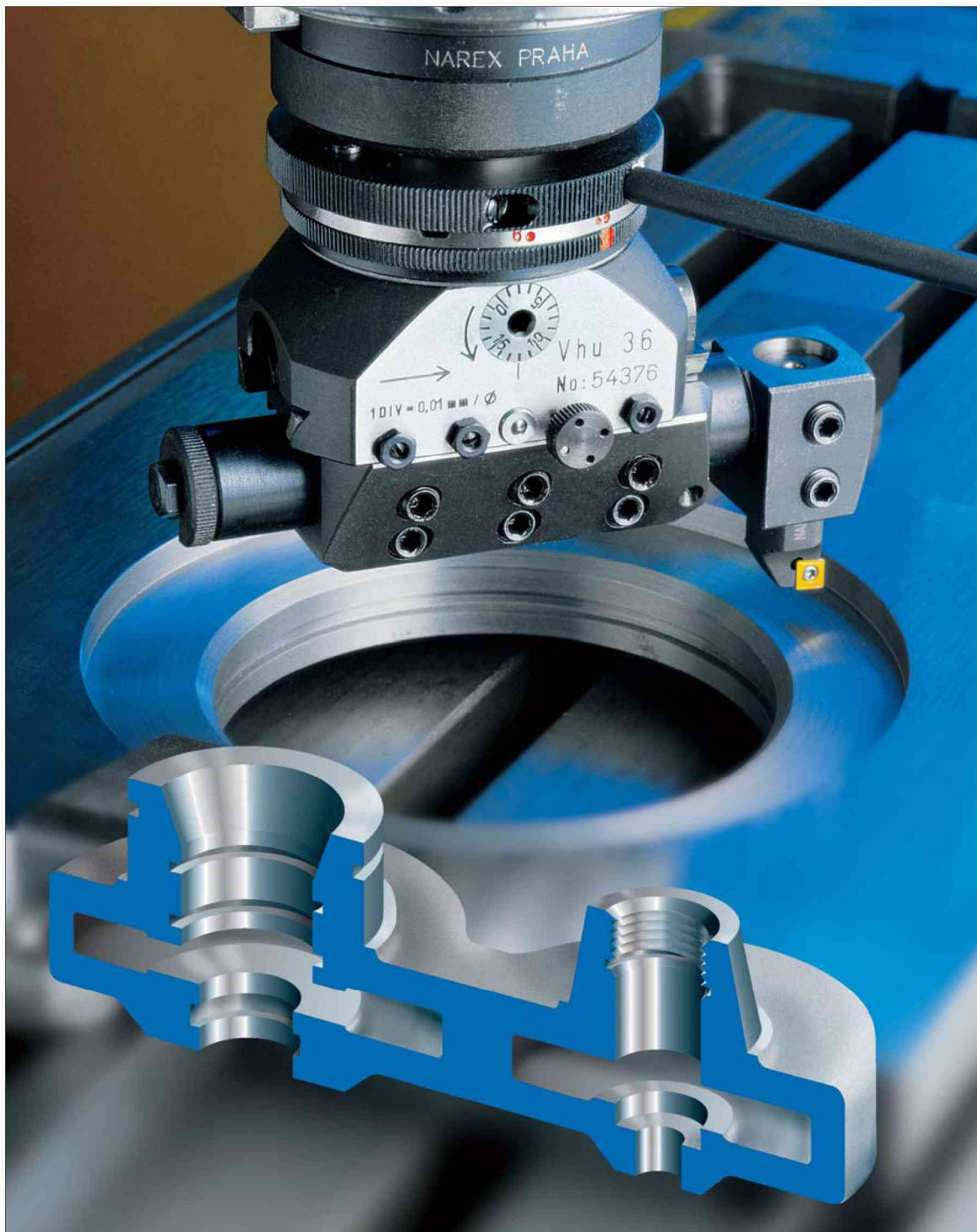
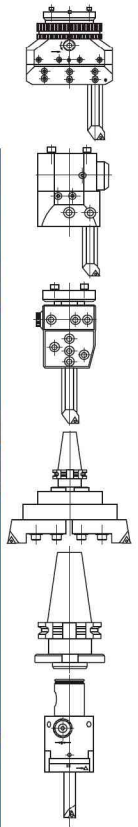

PANAS Tools s.r.o., Hradište 371, 958 54 Hradište-SK, info@panas.sk, www.panas.sk

NAREX  MTE[®]

A 1.00

VYVRTÁVACÍ HLAVY UNIVERZÁLNÍ – Vhu

UNIVERSAL BORING HEADS – Vhu

CABEZALES ALESADORES UNIVERSALES – Vhu



LEGENDA – LEGEND – LEYENDA

- 5 – spojka – clutch – acoplamiento
- 6 – brzdící kroužek – braking ring – anillo de freno
- 27 – saně – slide – guías
- 34 – šroub – screw – tornillo
- 41 – šnek se stupnicí – worm with scale – tornillo sin fin con escala
- 46 – těleso – body – cuerpo
- 50 – zastavovací tyč – stopping bar – vástago de freno
- K – kuželová stopka – taper shank – espiga cónica

Vhu – jako vyvrtávací přístroj – značně rozšiřuje možnosti vyvrtávacích strojů, vrtaček, frézek apod. Hlavy se používají k přesnému vyvrtávání válcových otvorů a obrábění vnějších válcových ploch. Při použití samočinného posuvu saní lze hlavou obrábět čelní plochy otvorů, zapichovat a vyvrtávat kuželové plochy.

Posuv saní je seřiditelný ve 3 až 4 velikostech a vypíná se samočinně na nastaveném dorazu kolíčkovou spojkou. Posuv je odvozen od rotačního pohybu hlavy za předpokladu, že je zvolen jeden z posuvů, kolíček spojky je zasunut a brzdící kroužek hlavy je zastaven zastavovací tyčí.

Šroub (34) slouží k rychlému přesunutí saní a šnek se stupnicí (41) naopak k nastavování rozměru při přesném vyvrtávání (1 dílek = vysunutí saní o 0,05 mm).

Hlavy jsou dodávány včetně základního příslušenství ve dřevěné kazetě. Upínací kuželová stopka je vyměnitelná a není součástí příslušenství, a proto je třeba ji objednávat zvlášť.

Hlavy Vhu 110/Vhu 160 jsou modifikací základního provedení Vhu 80/Vhu 125 – mají prodloužené saně včetně prodlouženého šroubu.

ZÁKLADNÍ TECHNICKÉ PARAMETRY – BASIC TECHNICAL DATA – PARÁMETROS TÉCNICOS PRINCIPALES

	Vhu	36	56	80	110	125	160
Pohyb saní – Slide motion – Avance de guías	max. [mm]	36	56	80	110	125	160
Obráběný průměr čela – Facing diameter – Diámetro labrado de la cara	max. [mm]	230	320	380	430	610	690
Vyvrtávaný průměr – Boring diameter – Diámetro alesado	max. [mm]	225	360	410	450	650	720
Samočinný posuv – Automatic feed – Avance automático	[mm.ot ⁻¹] [mm.rev ⁻¹] [mm.rev ⁻¹]	0,02 0,04 0,06	0,05 – 0,10 – 0,15 – 0,20				
Ruční rychloposuv – Hand rapid feed – Avance rápido manual	[mm.ot ⁻¹] [mm.rev ⁻¹] [mm.rev ⁻¹]	3				4	
Přesnost nastavování – Accuracy of adjustment – Precisión de ajuste							
Průměr upínacích otvorů – Diameter of clamping holes – Diámetro de agujeros de fijación	dH8 [mm]	16	25			32	
Hmotnost hlavy/kazety – Weight of head/set – Peso del cabezal/estuche y accesorios	[kg]	2,1/5,3	7,5/18,6	8,1/19,0	8,4/19,5	12,4/33,0	13,8/34,3
Kuželové stopky – Taper shanks – Espigas cónicas	VK	VK360	VK800, VK801			VK801	
Rozměry kazety – Dimensions of the wooden box – Dimensiones del estuche	[mm]	320 × 270 × 85	490 × 350 × 165			540 × 380 × 170	

ZÁKLADNÍ ROZMĚRY – BASIC DIMENSIONS – DIMENSIONES BÁSICAS

	Kód – Code – Código	A	B	C	D	E
Vhu 36	201.146 (model C)	78	78	28	53	100
Vhu 56	201.153 (model C)	115	115	36	80	134
Vhu 80	201.160 (model C)	140	140	36	80	134
Vhu 110	201.177 (model C)	165	140	36	80	134
Vhu 125	201.184 (model C)	190	190	42	92	151
Vhu 160	201.191 (model C)	225	190	42	92	159

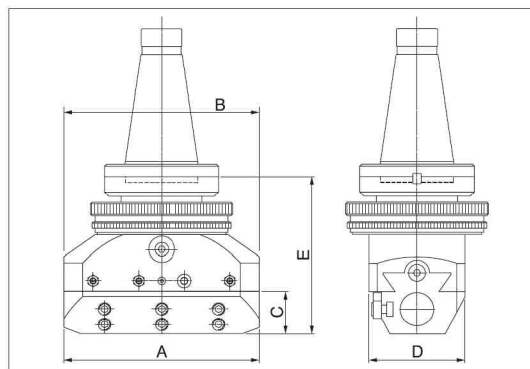

česky
english
español

Vhu - as a boring device - considerably increases possibilities of boring, drilling and milling machines. These heads are suitable for precision boring of cylindrical holes, and for machining of external cylindrical surfaces. The boring head Vhu by means of an automatic slide feed makes possible facing, backfacing and taper machining. The slide feed is adjustable in three or four grades and is stopped on adjustable dog by the pin clutch. The feed is derived from the rotary motion of the head, if one of the feed is adjusted, the pin of the clutch is put in and the brake ring is held by means of the stop bar. The screw (34) serves for quick adjusting of side and, on the contrary, the worm with the scale is used for fine adjusting of precision boring. (1 division = slide movement of 0,005 mm.)

These heads are delivered with primary accessories in wooden boxes. The taper shank is exchangeable and it is not a component of primary accessories. Therefore it is necessary to order taper shank as a special item.

The boring heads Vhu 110/Vhu 160 are modifications of the basic Vhu 80 resp. Vhu 125 types; they have extended slides and screws.

Vhu – instrumento de alesado – aumenta considerable la capacidad de alesar de alesadoras, taladradoras, fresadoras, etc.

Los cabezales se emplean para la perforación precisa de orificios cilíndricos y diámetros redondos exteriores. Al utilizar el avance automático de guías, se pueden labrar las caras de orificios, hacer troncos y alesar superficies cónicas. El avance de guías es programable, cuenta con 3 - 4 velocidades y se desconecta automáticamente llegando al tope programado mediante el acoplamiento de clavija. El movimiento rotativo del cabezal se deriva de la puesta en marcha del avance en el supuesto de que se haya programado uno de los avances, la clavija del acoplamiento está introducida y el anillo del freno del cabezal está parado mediante el vástago de freno.

El tornillo (34) sirve para un avance de guías rápido y el tornillo sin fin, al contrario, sirve para ajustar las dimensiones a finalidad de conseguir alesado preciso.

(1 raya de graduación = avance de guías en 0,005 mm.)

Los cabezales se suministran junto con el accesorio básico en un estuche de madera. La espiga de sujeción cónica se puede cambiar y no forma parte del accesorio básico. Hay que solicitarla en un pedido especial.

Cabezal Vhu 110 / Vhu 160 es modificación del modelo primitivo Vhu 80 / Vhu 125 - dispone de guías alargadas, incluido el tornillo alargado.



Vhu 36

Vhu 56

Vhu 80

Vhu 125

ZÁKLADNÍ STROJNÍ OPERACE PROVÁDĚNÉ POMOCÍ Vhu

BASIC MACHINING OPERATIONS CARRIED OUT BY THE BORING HEADS Vhu

OPERACIONES BÁSICAS MECÁNICAS REALIZADAS CON Vhu

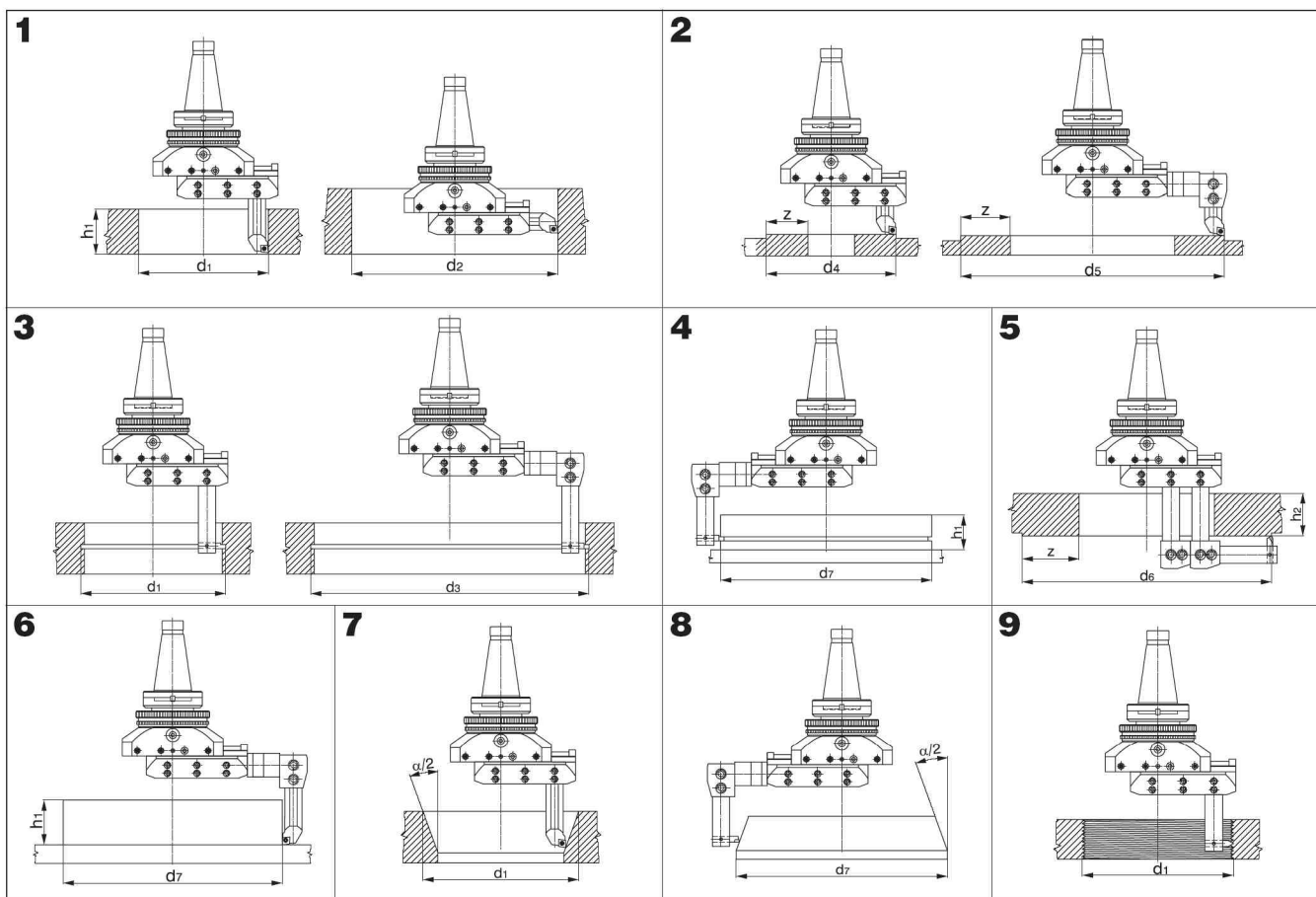

	Z _{max} [mm]	d _{max} [mm]							h _{max} [mm]	
		d ₁	d ₂	d ₃	d ₄	d ₅	d ₆	d ₇	h ₁	h ₂
Vhu 36	36	92	160	225	88	230	200	200	45	80
Vhu 56	56	170	250	360	210	320	300	280	125	85
Vhu 80	80	210	300	410	180	380	380	320	125	110
Vhu 110	110	270	340	450	240	430	430	370	125	110
Vhu 125	125	280	390	650	245	610	600	530	205	115
Vhu 160	160	350	480	720	340	690	690	610	205	115

POPIS – DESCRIPTION – DESCRIPCIÓN

1	Vyvrátání otvoru	Boring	Alesado de orificio
2	Zarovnávání předního čela	Facing	Rasadura de cara frontal
3	Vnitřní zapichování	Internal recessing	Tronzado interior
4	Vnější zapichování	Recessing	Tronzado exterior
5	Zarovnávání zadního čela	Back facing	Rasadura de cara trasera
6	Obrábění vnější válcové plochy	Machining of external cylindrical surface	Mecanizado de superficie cilíndrica exterior
7	Vyvrátání kuželového otvoru	Boring of taper hole	Alesado de orificio cónico
8	Obrábění vnější kuželové plochy	Machining of external taper	Mecanizado de superficie cónica exterior
9	Řezání závitu	Thread cutting	Corte de roscas

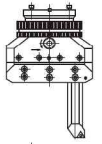

Vhu 36-D NAREX



Vhu 80-D NAREX



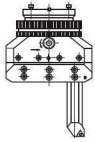

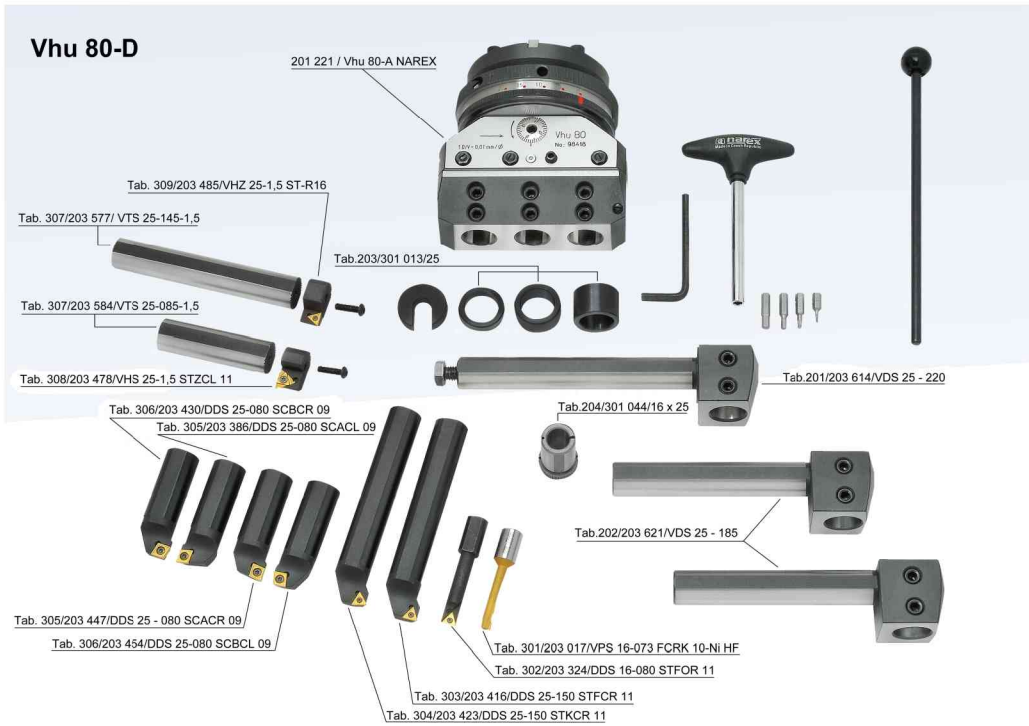
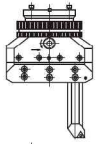

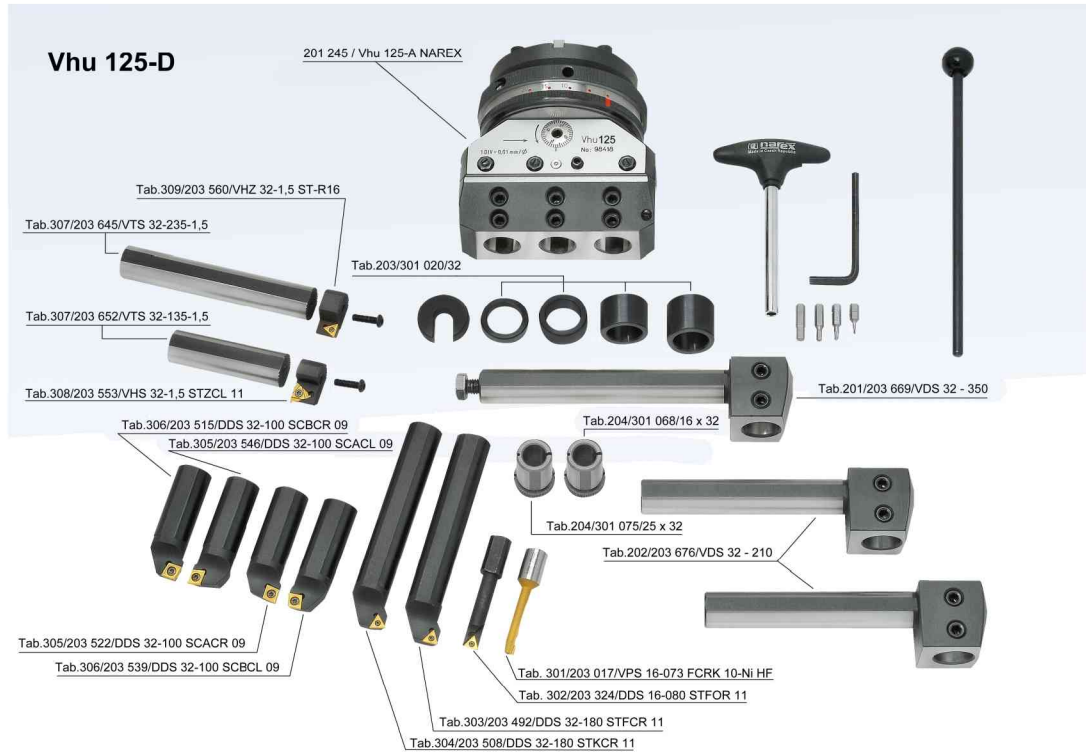

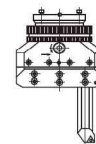

Vyvrtačací nože Boring Tools

Tab.303 / DDS - STFCR

Tab.304/ DDS - STKCR

Tab.309/ VHZ

Tab.308/ VHS

Tab.306 / DDS - SCBCL

Tab.305 / DDS - SCACL

Tab.305/ DDS - SCACR

Tab.306/ DDS - SCBCR

Tab.301 / VPS FCRK 10-Ni

Tab.302 / DDS - STFOR

Tab.307/ VTS

www.narexmte.cz

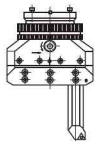

česky
english

PRODEJNÍ KOMPLETY - SPECIFIKACE PŘÍSLUŠENSTVÍ - SPECIFICATION OF ACCESSORIES IN SETS									
A	B	C	D	T	ČÍSLO TABULKY TABULATION No.				
 Hlava Vhu bez příslušenství Plain boring head	 Hlava Vhu se základním příslušenstvím Boring head with primary accessories	 Hlava Vhu s kompletním příslušenstvím bez VBD Boring head with complete accessories (no inserts)	 Hlava Vhu s kompletním příslušenstvím s VBD Boring head with complete accessories incl. inserts	 Pro vyvrtávací hlavu For Boring Head Vhu 36 Pro vyvrtávací hlavu For Boring Head Vhu 56, 80, 110, 125, 160					
				ZÁKLADNÍ PŘÍSLUŠENSTVÍ - PRIMARY ACCESSORIES					201
								202	
								203	
								204	
								205	
								206	
								207	
								208	
				NOŽOVÉ PŘÍSLUŠENSTVÍ - TOOL ACCESSORIES					301
								302	
								303	
								304	
								305	
								305	
								306	
								306	
307									
308									
309									
VBD									
Hlava Vhu bez příslušenství Plain boring head	Hlava Vhu se základním příslušenstvím Boring head with primary accessories	Hlava Vhu s kompletním příslušenstvím bez VBD Boring head with complete accessories (no inserts)	Hlava Vhu s kompletním příslušenstvím s VBD Boring head with complete accessories incl. inserts	Hlava Vhu s optimalizovaným příslušenstvím Boring head with option					

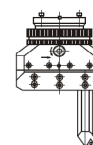

česky
english

ČÍSLO TABULKY TABULATION No.	SEZNAM PŘÍSLUŠENSTVÍ LIST OF ACCESSORIES	Vhu					
		x - číslo řádky v příslušné tabulce xx - počet kusů v kompletu x - line number in the relevant table xx - number of pieces in the set					
		36	56	80	110	125	160
201	držák se šroubem Holder with screw	1 1 ks/Pc	2 1 ks/Pc	3 1 ks/Pc	4 1 ks/Pc	5 1 ks/Pc	6 1 ks/Pc
202	držák Holder		1 2 ks/Pc	2 2 ks/Pc	2 2 ks/Pc	3 2 ks/Pc	3 2 ks/Pc
203	trubka - sada Set of spacing tubes	1 1 sada/set	2 1 sada/set	2 1 sada/set	2 1 sada/set	3 1 sada/set	3 1 sada/set
204	redukční pouzdro Reduction sleeve	1 1 ks/Pc	2 1 ks/Pc	2 1 ks/Pc	2 1 ks/Pc	4 1 ks/Pc	4 1 ks/Pc
205	zastavovací tyč Stopping bar	1 1 ks/Pc	2 1 ks/Pc	2 1 ks/Pc	2 1 ks/Pc	3 1 ks/Pc	3 1 ks/Pc
206	šroubovák s T rukojetí Screwdriver with T-handle	1 1 ks/Pc	1 1 ks/Pc	1 1 ks/Pc	1 1 ks/Pc	1 1 ks/Pc	1 1 ks/Pc
207	zástrčný bit Screwdriver bit	1 1 ks/Pc	1+2 1 ks/Pc	1+2 1 ks/Pc	1+2 1 ks/Pc	1+2 1 ks/Pc	1+2 1 ks/Pc
208	šroubovákový nástavec Screwdriver	1 1 ks/Pc	1+2 1 ks/Pc	1+2 1 ks/Pc	1+2 1 ks/Pc	1+2 1 ks/Pc	1+2 1 ks/Pc
301	nůž Boring tool	1+2 1 ks/Pc	2 1 ks/Pc	2 1 ks/Pc	2 1 ks/Pc	2 1 ks/Pc	2 1 ks/Pc
302	držák VBD STFOR 11 Insert holder VBD STFOR 11	1 1 ks/Pc	1 1 ks/Pc	1 1 ks/Pc	1 1 ks/Pc	1 1 ks/Pc	1 1 ks/Pc
303	držák VBD STFCR 11 Insert holder VBD STFCR 11	1 1 ks/Pc	2 1 ks/Pc	2 1 ks/Pc	2 1 ks/Pc	3 1 ks/Pc	3 1 ks/Pc
304	držák VBD STKCR 11 Insert holder VBD STKCR 11	1 1 ks/Pc	2 1 ks/Pc	2 1 ks/Pc	2 1 ks/Pc	3 1 ks/Pc	3 1 ks/Pc
305	držák VBD SCACL Insert holder VBD SCACL	2 1 ks/Pc	4 1 ks/Pc	4 1 ks/Pc	4 1 ks/Pc	6 1 ks/Pc	6 1 ks/Pc
305	držák VBD SCACR Insert holder VBD SCACR	1 1 ks/Pc	3 1 ks/Pc	3 1 ks/Pc	3 1 ks/Pc	5 1 ks/Pc	5 1 ks/Pc
306	držák VBD SCBCL Insert holder VBD SCBCL	2 1 ks/Pc	4 1 ks/Pc	4 1 ks/Pc	4 1 ks/Pc	6 1 ks/Pc	6 1 ks/Pc
306	držák VBD SCBCR Insert holder VBD SCBCR	1 1 ks/Pc	3 1 ks/Pc	3 1 ks/Pc	3 1 ks/Pc	5 1 ks/Pc	5 1 ks/Pc
307	držák hlavice Insert holder bar	1 1 ks/Pc	2+3 1 ks/Pc	2+3 1 ks/Pc	2+3 1 ks/Pc	4+5 1 ks/Pc	4+5 1 ks/Pc
308	hlavice zadní Back insert holder	1 1 ks/Pc	2 1 ks/Pc	2 1 ks/Pc	2 1 ks/Pc	3 1 ks/Pc	3 1 ks/Pc
309	hlavice závit - zápich Insert holder thread - recess	1 1 ks/Pc	2 1 ks/Pc	2 1 ks/Pc	2 1 ks/Pc	3 1 ks/Pc	3 1 ks/Pc
	WOHLHAUPTER tvar/form 161 WTI 12 097512 1a*)	4 ks/Pc	4 ks/Pc	4 ks/Pc	4 ks/Pc	4 ks/Pc	4 ks/Pc
	CCMT 060204E UM 8016 CCMT 09T304E	4 ks/Pc	4 ks/Pc	4 ks/Pc	4 ks/Pc	4 ks/Pc	4 ks/Pc

KÓDOVÉ ZNAČENÍ KOMPLETU CODE NAME OF THE SET

A Pouze hlava v kartonovém obalu
Single head in pasteboard packing

Vhu 36 - A / 201 207

Vhu 56 - A / 201 214

Vhu 80 - A / 201 221

Vhu 110 - A / 201 238

Vhu 125 - A / 201 245

Vhu 160 - A / 201 252

B Hlava, základní příslušenství,
dřevěná kazeta
Head, primary accessories,
wooden box

Vhu 36 - B / 201 269

Vhu 56 - B / 201 276

Vhu 80 - B / 201 283

Vhu 110 - B / 201 290

Vhu 125 - B / 201 306

Vhu 160 - B / 201 313

C Hlava, základní a nožové
příslušenství, dřevěná kazeta
Head, primary accessories, tool
accessories, wooden box

Vhu 36 - C / 201 146

Vhu 56 - C / 201 153

Vhu 80 - C / 201 160

Vhu 110 - C / 201 177

Vhu 125 - C / 201 184

Vhu 160 - C / 201 191

D Hlava, základní a nožové
příslušenství, VBD, dřevěná kazeta
Head, primary and tool accessories,
indexable inserts, wooden box

Vhu 36 - D / 201 085

Vhu 56 - D / 201 092

Vhu 80 - D / 201 108

Vhu 110 - D / 201 115

Vhu 125 - D / 201 122

Vhu 160 - D / 201 139

T Hlava, základní a nožové příslušen.
- výběr "T", dřevěná kazeta
Head, primary and tool accessories
- choice "T", wooden box

Vhu 36 - T / 201 320

Vhu 56 - T / 201 337

Vhu 80 - T / 201 344

Vhu 110 - T / 201 351

Vhu 125 - T / 201 368

Vhu 160 - T / 201 375

*) dodává se buď 1a nebo 1b - dle objednávk
1b is supplied unless 1a required

Způsob objednávání a dodávání: Nožové příslušenství je dodáváno buď v rámci kompletů C nebo D, řezné destičky nejsou součástí držáků. Je možno objednávat držáky samostatně pomocí označení a kódového čísla.

Poznámka: Břitové destičky pro závit a zápichy naše firma nedrží skladem.

POZOR: Pokud nebude dána specifikace VBD
1a nebo 1b, budou dodány VBD 1b.

The tool accessories are delivered either as a set C or D, indexable inserts are not included in holders. Insert holders may be ordered separately by means of the name and code number.

PANAS Tools s.r.o., Hradište 371, 958 54 Hradište-SK, info@panas.sk, www.panas.sk

Vhu - NOŽOVÉ PŘÍSLUŠENSTVÍ

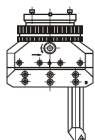

Na základě požadavků na zvýšení kvality vyvrtávání při vysoké produktivitě a rovněž na zvýšení životnosti nožů a jejich rychlé obměny, provedla naše firma inovaci nožového příslušenství pro vyvrtávání, které uvádí na trh především v souvislosti s výrobkem Vhu.

česky

Co bylo nahrazeno:

Nože z oceli HSS, vyvrtávací tyče, nože s pájeným plátkem.

Čím bylo nahrazeno:

- 1) Nože 301 s pájenou břitovou destičkou povlakovanou TiN s pozitivní geometrií ostří - určeno pro přesné vyvrtávání otvorů od \varnothing 6 mm. Jsou možné velmi malé úběry až 0,05 mm s kvalitním povrchem obrobené plochy.
- 2) Držáky VBD 302, 303 a 304 jsou osazeny trojúhelníkovou břitovou destičkou se 3 břity a malým radiusem na špičce. To umožňuje přesné vyvrtávání i při malých úběrech (0,05 mm). Je možné použít i destičku od firmy Wohlhaupter - tvar 161, která je broušená a má velmi pozitivní geometrii ostří.
To dovoluje extrémně malé úběry - až 0,02 mm při záruce vysoké jakosti obráběné plochy.
- 3) Držáky VBD 305 a 306 nahrazují přímé nože s pájenou destičkou, určené především pro zarovnávání předních čel otvorů a dále pro vyvrtávání velkých otvorů - nůž je upnut v příčném otvoru saní.
- 4) Vyvrtávací hlavice 308 a 309 se upínají na držák hlavice 307 a slouží k provádění operací dle jejich názvu. Hlavice zadní slouží k zarovnávání zadních čel otvorů, hlavice závit - zápich lze použít k závitování nebo zapichování v otvoru nebo i na vnějším povrchu.

Výhody použití tohoto nářadí:

- větší trvanlivost ostří
- možnost produktivně a přesně vyvrtávat i při nedokonalém nebo žádném chlazení
- při použití VBD není třeba ostření břitů, rychlá výměna
- VBD firmy Wohlhaupter zaručují velmi vysokou kvalitu vyvrtávání
- Při obrábění větších průměrů už od \varnothing 50 mm lze obrábět při optimálních řezných rychlostech, což podstatně zvyšuje produktivitu proti původním možnostem.

Informace:

- Od 1.1. 2004 bude zaveden nový způsob objednávání a dodávání Vhu-hlav. Důvodem je inovační změna především v nožovém vybavení a tomu odpovídající cena kompletu - D.
- Variabilita objednávání umožňuje objednateli sestavit požadavek dle své konkrétní představy v rámci některého z kompletů a nebo je možné nožové příslušenství vybrat po požadovaných položkách.
- Řezné destičky VBD nejsou součástí držáků.
- Upínací kuželové stopky nejsou součástí Vhu - hlav.
- Provedení "T" odpovídá cenám a užití - původní sestavy.

Vhu - TOOL ACCESSORIES

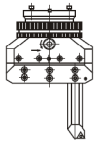

english

Our firm has realized the innovation of the tool accessories for boring according to demands on increasing the quality of boring, high productivity and tool life.

REPLACED TOOLS

OLD:

HSS tools, boring bars, brazed tools

NEW:

- 1) The brazed tools 301 with TiN coated insert with positive geometry are specified for precise boring from \varnothing 6 mm. The very small depth of cut up to 0,05 mm with high quality of machined surface is possible.
- 2) The insert holders 302, 303 and 304 are equipped with triangular insert with 3 cutting edges and small corner radius, making possible precise boring with very small depth of cut (0,05 mm). It is possible to use the insert Wohlhaupter - form 161, ground, with high positive geometry for extremely small depth of cut up to 0,02 mm with guaranteed high quality of machined surface
- 3) The insert holders 305 and 306 replace the brazed straight tools specified for facing and boring of great holes – the tool is clamped in the cross boring of the slide.
- 4) The insert holders 308 and 309 are clamped on the bar 307. The back insert holder 308 makes possible back facing, the insert holder recess – thread 309 is designed for recessing or thread cutting in the bore or on the external surface.

ADVANTAGES:

- longer working life
- possibility of productive and precise boring with imperfect or no cooling
- there is no need to resharpen the cutting edges, quick exchange
- very high quality of boring
- it is possible to machine bore of greater diameters even from 50 mm at optimum cutting conditions and higher productivity than before

INFORMATION:

- The new method of ordering and delivery of boring heads Vhu will be initiated since 1st January 2004 regarding to the innovation of the tool accessories and corresponding price of the set D.
- The variability of ordering makes possible to specify the order according to customer s requirements within some of sets or to select the separate items of the tool accessories.
- The indexable inserts are not included in holders.
- The taper shanks are not included in boring heads Vhu.
- Model "T" corresponds to the old execution in price and in use.

ZÁKLADNÍ PŘÍSLUŠENSTVÍ - PRIMARY ACCESSORIES



česky
english

201 DRŽÁK SE ŠROUBEM - HOLDER WITH SCREW

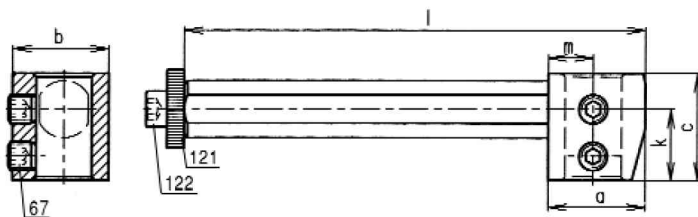

	Kód Code	Značení Description	Rozměry (mm) - Dimensions (mm)							kg	67 šroub Screw	122 šroub Screw	121 podložka Washer	Použití For
			a	b	c	d	k	l	m					
1	203 706	VDS 16 - 132	27	27	30	16	20	132	13	0,28	M8×1 - 10	M6-25	6	Vhu 36
2	203 591	VDS 25 - 195	45	46	46	25	33	195	22,5	0,95	M12×1 - 15	M12-40	12	Vhu 56
3	203 614	VDS 25 - 220	45	46	46	25	33	220	22,5	1,1	M12×1 - 15	M12-40	12	Vhu 80
4	203 638	VDS 25 - 244	45	46	46	25	33	244	22,5	1,18	M12×1 - 15	M12-40	12	Vhu 110
5	203 669	VDS 32 - 350	50	56	56	32	39	350	22,5	2,5	M12×1 - 15	M12-40	12	Vhu 125
6	203 683	VDS 32 - 383	50	56	56	32	39	383	22,5	2,75	M12×1 - 15	M12-40	12	Vhu 160

202 DRŽÁK VBD - HOLDER

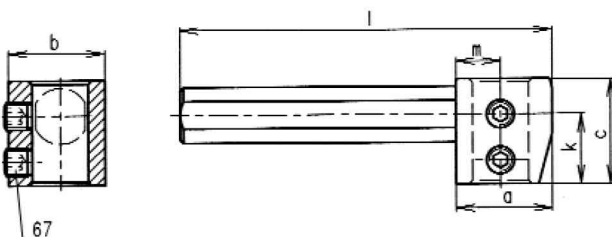

	Kód Code	Značení Description	Rozměry (mm) - Dimensions (mm)							kg	67 šroub Screw	Použití For
			a	b	c	d	k	l	m			
1	203 607	VDS 25 - 160	45	46	46	25	33	160	22,5	0,9	M12×1 - 15	Vhu 56
2	203 621	VDS 25 - 185	45	46	46	25	33	185	22,5	1,0	M12×1 - 15	Vhu 80, Vhu 110
3	203 676	VDS 32 - 210	50	56	56	32	39	210	22,5	1,7	M12×1 - 15	Vhu 125, Vhu 160

203 TRUBKA - SADA - SET OF SPACING TUBES

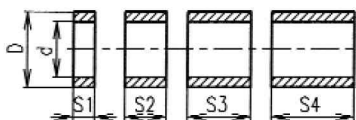

	Kód Code	Značení Description	ks/sada	Rozměry (mm) - Dimensions (mm)		
				d	D	S1/S2/S3/S4
1	301 006	TRUBKA - SADA 16	3	16,2	22	6/12/18
2	301 013	TRUBKA - SADA 25	3	25,5	35	18/16/25
3	301 020	TRUBKA - SADA 32	4	32,3	44	12/24/36/50

204 REDUKČNÍ POUZDRO - REDUCTION SLEEVE

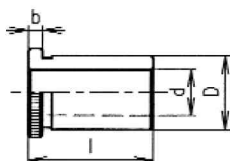

	Kód - Code	d×D	l/b	kg	Použití - For
1	301 037	10×16	30/5	0,03	Vhu 36
2	301 044	16×25	42/6	0,09	Vhu 56, 80, 110
3	301 051	20×25	42/6	0,06	Vhu 56, 80, 110
4	301 068	16×32	56/6	0,25	Vhu 125, 160
5	301 075	25×32	56/6	0,18	Vhu 125, 160
6	301 082	20×32	56/6	0,20	Vhu 125, 160

● standard ■ k poptání - for demand

NOŽOVÉ PŘÍSLUŠENSTVÍ - TOOL ACCESSORIES

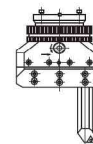

česky
english

301 NŮŽ - BORING TOOL

FCRK 10 - Ni HF

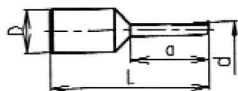

	Kód Code	Značení Description	Rozměry (mm) - Dimensions (mm)				kg	použití From od Ø
			D	d	L	a		
1	203 201	VPS 16 - 062 FCRK 10-Ni HF 658 00550	16	5,5	60	30	0,05	6
2	203 317	VPS 16 - 073 FCRK 10-Ni HF 658 00550	16	9,5	73	43	0,06	10

302 DRŽÁK - INSERT HOLDER

STFCR 11

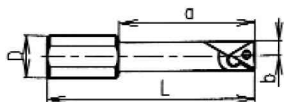

	Kód Code	Značení Description	Rozměry (mm) - Dimensions (mm)				kg	použití From od Ø
			D	b	L	a		
1	203 324	DDS 16 - 080 STFCR 11	16	5,9	80	53	0,09	12

code-kód: 203 874
code-kód: 203 829

Wohlhaupter tvar 161 WTI 12 097512
Pramet TCMT 110202 E - UM 8016

US 2505

303 DRŽÁK VBD - INSERT HOLDER

STFCR 11

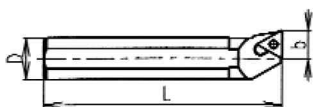

	Kód Code	Značení Description	Rozměry (mm) - Dimensions (mm)			kg	použití From od Ø
			D	b	L		
1	203 331	DDS 16 - 090 STFCR 11	16	11	90	0,12	20
2	203 416	DDS 25 - 150 STFCR 11	25	17	150	0,51	32
3	203 492	DDS 32 - 180 STFCR 11	32	22	180	0,97	38

code-kód: 203 874
code-kód: 203 829

Wohlhaupter tvar 161 WTI 12 097512
Pramet TCMT 110202 E - UM 8016

US 2505

304 DRŽÁK VBD - INSERT HOLDER

STKCR 11

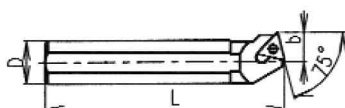

	Kód Code	Značení Description	Rozměry (mm) - Dimensions (mm)			kg	použití From od Ø
			D	b	L		
1	203 348	DDS 16 - 090 STKCR 11	16	11	90	0,12	20
2	203 423	DDS 25 - 150 STKCR 11	25	17	150	0,51	32
3	203 508	DDS 32 - 180 STKCR 11	32	22	180	0,97	38

code-kód: 203 874
code-kód: 203 829

Wohlhaupter tvar 161 WTI 12 097512
Pramet TCMT 110202 E - UM 8016

US 2505

305 DRŽÁK VBD - INSERT HOLDER

SCACR/L

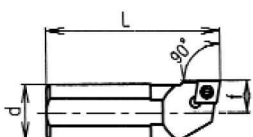

	Kód Code	Značení Description	Rozměry (mm) - Dimensions (mm)			kg	R - pravý/right L - levý/left
			D	L	f		
1	203 355	DDS 16 - 050 SCACR 06	16	50	9	0,06	R
2	203 386	DDS 16 - 050 SCACL 06	16	50	9	0,06	L
3	203 447	DDS 25 - 080 SCACR 09	25	80	14	0,25	R
4	203 461	DDS 25 - 080 SCACL 09	25	80	14	0,25	L
5	203 522	DDS 32 - 100 SCACR 09	32	100	17	0,53	R
6	203 546	DDS 32 - 100 SCACL 09	32	100	17	0,53	L

code-kód: 203 829
code-kód: 203 843

DDS 16: CCMT 060204E-UM8016
DDS 25, DDS 32: CCMT 09T304E-UM8016

DDS 16: US 2505
DDS 25, 32: US-13

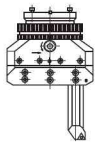

306 DRŽÁK VBD - INSERT HOLDER VBD		SCBCR/L																																																																				
				<table border="1"> <thead> <tr> <th rowspan="2">Kód Code</th> <th rowspan="2">Značení Description</th> <th colspan="3">Rozměry (mm) - Dimensions (mm)</th> <th rowspan="2">kg</th> <th rowspan="2">R - pravý/right L - levý/left</th> </tr> <tr> <th>D</th> <th>L</th> <th>f</th> </tr> </thead> <tbody> <tr> <td>1</td> <td>203 362</td> <td>DDS 16 - 050</td> <td>SCBCR 06</td> <td>16</td> <td>50</td> <td>9</td> <td>0,06</td> <td>R</td> </tr> <tr> <td>2</td> <td>203 379</td> <td>DDS 16 - 050</td> <td>SCBCL 06</td> <td>16</td> <td>50</td> <td>9</td> <td>0,06</td> <td>L</td> </tr> <tr> <td>3</td> <td>203 430</td> <td>DDS 25 - 080</td> <td>SCBCR 09</td> <td>25</td> <td>80</td> <td>14</td> <td>0,25</td> <td>R</td> </tr> <tr> <td>4</td> <td>203 454</td> <td>DDS 25 - 080</td> <td>SCBCL 09</td> <td>25</td> <td>80</td> <td>14</td> <td>0,25</td> <td>L</td> </tr> <tr> <td>5</td> <td>203 515</td> <td>DDS 32 - 100</td> <td>SCBCR 09</td> <td>32</td> <td>100</td> <td>17</td> <td>0,53</td> <td>R</td> </tr> <tr> <td>6</td> <td>203 539</td> <td>DDS 32 - 100</td> <td>SCBCL 09</td> <td>32</td> <td>100</td> <td>17</td> <td>0,53</td> <td>L</td> </tr> </tbody> </table>			Kód Code	Značení Description	Rozměry (mm) - Dimensions (mm)			kg	R - pravý/right L - levý/left	D	L	f	1	203 362	DDS 16 - 050	SCBCR 06	16	50	9	0,06	R	2	203 379	DDS 16 - 050	SCBCL 06	16	50	9	0,06	L	3	203 430	DDS 25 - 080	SCBCR 09	25	80	14	0,25	R	4	203 454	DDS 25 - 080	SCBCL 09	25	80	14	0,25	L	5	203 515	DDS 32 - 100	SCBCR 09	32	100	17	0,53	R	6	203 539	DDS 32 - 100	SCBCL 09	32	100	17	0,53	L
Kód Code	Značení Description	Rozměry (mm) - Dimensions (mm)			kg	R - pravý/right L - levý/left																																																																
		D	L	f																																																																		
1	203 362	DDS 16 - 050	SCBCR 06	16	50	9	0,06	R																																																														
2	203 379	DDS 16 - 050	SCBCL 06	16	50	9	0,06	L																																																														
3	203 430	DDS 25 - 080	SCBCR 09	25	80	14	0,25	R																																																														
4	203 454	DDS 25 - 080	SCBCL 09	25	80	14	0,25	L																																																														
5	203 515	DDS 32 - 100	SCBCR 09	32	100	17	0,53	R																																																														
6	203 539	DDS 32 - 100	SCBCL 09	32	100	17	0,53	L																																																														
code - kód: 203 829 code - kód: 203 843		DDS 16: CCMT 060204E-UM8016 DDS 25, DDS 32: CCMT 09T304E UM8016		DDS 16: US 2505 DDS 25, 32: US-13			T 7 T15																																																															

307 DRŽÁK HLAVICE - HOLDER BAR		VTS																																																						
				<table border="1"> <thead> <tr> <th rowspan="2">Kód Code</th> <th rowspan="2">Značení Description</th> <th colspan="3">Rozměry (mm) - Dimensions (mm)</th> <th rowspan="2">kg</th> <th rowspan="2">Použití To</th> </tr> <tr> <th>D</th> <th>L</th> <th>t</th> </tr> </thead> <tbody> <tr> <td>1</td> <td>203 690</td> <td>VTS 16 - 075 - 1,5</td> <td>16</td> <td>75</td> <td>1,5</td> <td>0,11</td> <td>VHS 16, VHZ 16</td> </tr> <tr> <td>2</td> <td>203 584</td> <td>VTS 25 - 085 - 1,5</td> <td>25</td> <td>85</td> <td>1,5</td> <td>0,31</td> <td>VHS 25, VHZ 25</td> </tr> <tr> <td>3</td> <td>203 577</td> <td>VTS 25 - 145 - 1,5</td> <td>25</td> <td>145</td> <td>1,5</td> <td>0,51</td> <td>VHS 25, VHZ 25</td> </tr> <tr> <td>4</td> <td>203 652</td> <td>VTS 32 - 135 - 1,5</td> <td>32</td> <td>135</td> <td>1,5</td> <td>0,78</td> <td>VHS 32, VHZ 32</td> </tr> <tr> <td>5</td> <td>203 645</td> <td>VTS 32 - 235 - 1,5</td> <td>32</td> <td>235</td> <td>1,5</td> <td>1,40</td> <td>VHS 32, VHZ 32</td> </tr> </tbody> </table>			Kód Code	Značení Description	Rozměry (mm) - Dimensions (mm)			kg	Použití To	D	L	t	1	203 690	VTS 16 - 075 - 1,5	16	75	1,5	0,11	VHS 16, VHZ 16	2	203 584	VTS 25 - 085 - 1,5	25	85	1,5	0,31	VHS 25, VHZ 25	3	203 577	VTS 25 - 145 - 1,5	25	145	1,5	0,51	VHS 25, VHZ 25	4	203 652	VTS 32 - 135 - 1,5	32	135	1,5	0,78	VHS 32, VHZ 32	5	203 645	VTS 32 - 235 - 1,5	32	235	1,5	1,40	VHS 32, VHZ 32
Kód Code	Značení Description	Rozměry (mm) - Dimensions (mm)			kg	Použití To																																																		
		D	L	t																																																				
1	203 690	VTS 16 - 075 - 1,5	16	75	1,5	0,11	VHS 16, VHZ 16																																																	
2	203 584	VTS 25 - 085 - 1,5	25	85	1,5	0,31	VHS 25, VHZ 25																																																	
3	203 577	VTS 25 - 145 - 1,5	25	145	1,5	0,51	VHS 25, VHZ 25																																																	
4	203 652	VTS 32 - 135 - 1,5	32	135	1,5	0,78	VHS 32, VHZ 32																																																	
5	203 645	VTS 32 - 235 - 1,5	32	235	1,5	1,40	VHS 32, VHZ 32																																																	
Náhradní díly - Spare parts		M6x20 07150			6hran 4																																																			

308 HLAVICE ZADNÍ - BACK FACE INSERT HOLDER		STZCL 11																																															
				<table border="1"> <thead> <tr> <th rowspan="2">Kód Code</th> <th rowspan="2">Značení Description</th> <th colspan="5">Rozměry (mm) - Dimensions (mm)</th> <th rowspan="2">kg</th> </tr> <tr> <th>a</th> <th>b</th> <th>c</th> <th>d</th> <th>e</th> </tr> </thead> <tbody> <tr> <td>1</td> <td>203 393</td> <td>VHS 16 - 1,5</td> <td>STZCL 11</td> <td>14</td> <td>27</td> <td>15</td> <td>19</td> <td>11</td> <td>0,02</td> </tr> <tr> <td>2</td> <td>203 478</td> <td>VHS 25 - 1,5</td> <td>STZCL 11</td> <td>23</td> <td>35</td> <td>15</td> <td>23</td> <td>11</td> <td>0,06</td> </tr> <tr> <td>3</td> <td>203 553</td> <td>VHS 32 - 1,5</td> <td>STZCL 11</td> <td>29</td> <td>43</td> <td>15</td> <td>27</td> <td>11</td> <td>0,09</td> </tr> </tbody> </table>			Kód Code	Značení Description	Rozměry (mm) - Dimensions (mm)					kg	a	b	c	d	e	1	203 393	VHS 16 - 1,5	STZCL 11	14	27	15	19	11	0,02	2	203 478	VHS 25 - 1,5	STZCL 11	23	35	15	23	11	0,06	3	203 553	VHS 32 - 1,5	STZCL 11	29	43	15	27	11	0,09
Kód Code	Značení Description	Rozměry (mm) - Dimensions (mm)							kg																																								
		a	b	c	d	e																																											
1	203 393	VHS 16 - 1,5	STZCL 11	14	27	15	19	11	0,02																																								
2	203 478	VHS 25 - 1,5	STZCL 11	23	35	15	23	11	0,06																																								
3	203 553	VHS 32 - 1,5	STZCL 11	29	43	15	27	11	0,09																																								
code - kód: 203 289		Pramet TCMT 110202 E - UM 8016			US 2505			T 7																																									

309 HLAVICE ZÁVIT - ZÁPICH - RECESS/THREAD INSERT HOLDER		VHZ																																															
				<table border="1"> <thead> <tr> <th rowspan="2">Kód Code</th> <th rowspan="2">Značení Description</th> <th colspan="5">Rozměry (mm) - Dimensions (mm)</th> <th rowspan="2">kg</th> </tr> <tr> <th>a</th> <th>b</th> <th>c</th> <th>d</th> <th>e</th> </tr> </thead> <tbody> <tr> <td>1</td> <td>203 409</td> <td>VHZ 16 - 1,5</td> <td>ST - R16</td> <td>14</td> <td>27</td> <td>17</td> <td>21,5</td> <td>14,5</td> <td>0,02</td> </tr> <tr> <td>2</td> <td>203 485</td> <td>VHZ 25 - 1,5</td> <td>ST - R16</td> <td>23</td> <td>31,5</td> <td>17</td> <td>19,5</td> <td>14,5</td> <td>0,05</td> </tr> <tr> <td>3</td> <td>203 560</td> <td>VHZ 32 - 1,5</td> <td>ST - R16</td> <td>29</td> <td>36</td> <td>17</td> <td>21,5</td> <td>14,5</td> <td>0,08</td> </tr> </tbody> </table>			Kód Code	Značení Description	Rozměry (mm) - Dimensions (mm)					kg	a	b	c	d	e	1	203 409	VHZ 16 - 1,5	ST - R16	14	27	17	21,5	14,5	0,02	2	203 485	VHZ 25 - 1,5	ST - R16	23	31,5	17	19,5	14,5	0,05	3	203 560	VHZ 32 - 1,5	ST - R16	29	36	17	21,5	14,5	0,08
Kód Code	Značení Description	Rozměry (mm) - Dimensions (mm)							kg																																								
		a	b	c	d	e																																											
1	203 409	VHZ 16 - 1,5	ST - R16	14	27	17	21,5	14,5	0,02																																								
2	203 485	VHZ 25 - 1,5	ST - R16	23	31,5	17	19,5	14,5	0,05																																								
3	203 560	VHZ 32 - 1,5	ST - R16	29	36	17	21,5	14,5	0,08																																								
VBD Pramet TN 16 NR - *** ZZ *** A = šíře zápichu A: 1,10; 1,60; 2,15; 1,13; 1,85; 2,65 *** A = recess width		TN 16 NR *** M - metrický závit *** s = stoupání závitu s: 0,50; 1,00; 1,50; 2,00; 3,00; 0,75; 1,25; 1,75; 2,50			US 53			T 15																																									

KLÍČ K POPISU PŘÍSLUŠENSTVÍ

Označení držáků vyměnitelných břitových destiček, vyvrtávacích tyčí, držáků, výměnných hlavice

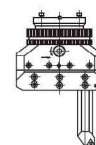

česky

DD		vyvrtávací nože - držáky destiček	upínací průměr D (mm)	délka vyvrtávacího nože (držáku) L (mm)	Způsob upínání destičky ISO
VP		vyvrtávací nože - s pájenou destičkou			
DV		držák destiček výsuvný - v. nůž	D1 - minimální - pro držák destiček výsuvný (DV)	D2- maximální pro - držák destiček výsuvný (DV)	
VD		vyvrtávací držáky	upínací průměr D (mm)	délka vyvrtávacího nože (držáku) L (mm)	
VT		vyvrtávací tyče, držáky hlavice			
VH		vyvrtávací hlavice pro držák hlavice průměru D	rozeč vodicích drážek t (**,*) (mm)		
					- bez upnutí destičky

D D S 1 6 - 0 8 7 S C G C L 0 9 X X X X

Doplňkový údaj - nepovinný - doporučený

S	bez vnitřního chlazení
A	s vnitřním chlazením
Z	závitovací hlavice

tvar nože - úhel nastavení - ISO										
A	B	C	D	D	D	E	F	G	H	J
90°	75°	90°	45°			60°	90°	90°	107°30'	93°
K	L	M	N	P	P	Q	R	S	S	T
75°	95°	50°	62°30'	117°30'		107°30'	75°	45°		60°
U	V	W	X	Y	Y	U	V	W	X	Y
93°	72°30'	60°	speciál	85°						
Z	- bez upnutí destičky									

tvar destičky - ISO	
S	
C	
D	
K	
V	

úhel hřbetu - ISO	WOHLHAUPTER		
α_n			
N	C	P	O
$\alpha_n=0^\circ$	$\alpha_n=7^\circ$	$\alpha_n=11^\circ$	$\alpha_n=10^\circ$

směr řezu - ISO	WOHLHAUPTER	
R	L	N
právy	levý	neutrální

velikost destičky - ISO	WOHLHAUPTER										
	tvar	S	C	D	V	K	W	T	R	W	T
d [mm]											
4,00										6.9	6.9
4,90											8.5
6,00									06		
6,35		06	07	11				11			
8,00											
9,525	09	09	11	16	19	06	16				
10,00									10		
12,00									12		
12,70	12	12				08	22	12			
15,875	15	16	15				27	15			
16,00								16			
19,05	19	19						19			
20,00								20			
25,00								25			
25,40	25	25						25			

KEY FOR DESCRIPTION OF ACCESSORIES

CODING



english

DD		boring tools – insert holders	clamping diameter D (mm)	length of boring tool (holder) L (mm)	clamping mode of insert ISO
VP		brazed boring tools			
DV		shifting insert holder	D1 - minimum – for shifting insert holder (DV)	D2- maximum - for shifting insert holder (DV)	
VD		holders	clamping diameter D (mm)	length of boring tool (holder) L (mm)	
VT		boring bars, insert holder bar			
VH		insert holder for insert holder bar diameter D	pitch of guiding grooves t (*,*) (mm)		
					- without clamping

D D S 1 6 - 0 8 7 S C G C L 0 9 X X X X

S	without internal cooling
A	with internal cooling
Z	thread cutting holder

form of insert ISO	
S	
C	
D	
K	
V	
T	
R	
W	
L	
X	special
-	without clamping

form of tool – cutting edge angle – ISO										
A	B	C	D	D	D	E	F	G	H	J
90°	75°	90°	45°			60°	90°	90°	107°30'	93°
K	L	M	N	P	P	Q	R	S	S	T
75°	95°	50°	62°30'	117°30'		107°30'	75°	45°		60°
U	V	W	X	Y	Y	U	V	W	X	Y
93°	72°30'	60°	special	85°						
Z	- without clamping									

recommended information only

clearance angle - ISO		WOHLHAUPTER
α_n		
N	C	P
$\alpha_n=0^\circ$	$\alpha_n=7^\circ$	$\alpha_n=11^\circ$
O		
$\alpha_n=10^\circ$		
cutting direction - ISO		WOHLHAUPTER
R	L	N
right	Left	neutral

size of insert - ISO									WOHLHAUPTER	
form	S	C	D	V	K	W	T	R	W	T
d [mm]										
4,00									6.9	6.9
4,90										8.5
6,00								06		
6,35		06	07	11			11			
8,00										
9,525	09	09	11	16	19	06	16			
10,00									10	
12,00									12	
12,70	12	12				08	22	12		
15,875	15	16	15				27	15		
16,00								16		
19,05	19	19						19		
20,00								20		
25,00								25		
25,40	25	25						25		

pozice position posición	Název dílu Part name Nombre de la parte	ks pcs pzs	Vhu 36	ks pcs pzs	Vhu 56	ks pcs pzs	Vhu 125
					Vhu 80		Vhu 160
			kód – code – código				kód – code – código
1	Šroub – screw – tornillo	4	309543005010	4	309543008016	4	309543008016
2	Kroužek – ring – anillo	1	412926001400	1	412926016700	1	412926033400
3	Kolík – pin – clavija	1	412926001500	1	311565002008	1	311565002008
4	Spojovací příruba – connection flange – brida de acoplamiento	1	412926008100	1	412926028800	1	412926039600
5	Pojistka – safety pin – seguro	1	412926004200	1	412926016900	1	412926016900
6	Brzdící kroužek – brake ring – anillo de freno	1	412926001500	1	412926016800	1	412926033500
7	Kroužek – ring – anillo	1	412926011500	1	412926017000	1	412926033600
8	Kolík – pin – clavija	2	311565002008	2	311565004010	2	311565004010
9	Ovládací kroužek – control ring – anillo de mando	1	412926001800	1	412926017200	1	412926033800
10	Pružina – spring – resorte	2	315110013330	1	315110003540	1	315110003540
11	Pružina – spring – resorte	6	315110003500	8	315110000000	8	315110000000
12	Kolík – pin – clavija	6	412926002100	8	412926017300	8	412926017300
13	Šroub – screw – tornillo	1	309303004008	1	412926021900	1	412926021900
14	Víčko – lid – tapón	1	412926011400	1	412926028300	1	412926031800
15	Podložka – washer – arandela	1	412926015800	1	412926021400	1	412926021400
16	Rohatka – ratchet wheel – rueda de trinquete	1	412926012800	1	412926018600	1	412926034800
17	Kroužek – ring – anillo	1	412926013100	1	412926018800	1	412926018800
18	Pravítko – bar – regla	1	412926012000	1	412926017800	1	412926034400
				1	412926027300		
				1	412926027300		
19	Šroub – screw – tornillo			1	309543008020	1	309543008020
20	Pružina – spring – resorte			1	315111000003	1	315111000003
21	Brzda – brake – freno			1	412926018700	1	412926032200
22	Kroužek – ring – anillo	2	412926013400	2	412926019200	2	412926035400
23	Kolík – pin – clavija	2	311565001605	2	311565002008	2	311565002008
24	Šroub – screw – tornillo	2	309543005010	4	309543008016	4	309543008016
25	Doraz – left dog – tope izquierdo	2	412926004400	1	412926018000	1	412926018000
26	Vložka – insert – buje	2	412926005500	2	412926017900	2	412926017900
27	Saně sestava – slide – guías-juego	1	412926012100	1	412926016500	1	412926033000
				1	412926027000	1	412926033200
				1	412926027200		
28	Západka – bar – trinquete	1	412926014700	1	412926019100	1	412926035300
29	Pružina – spring – resorte	1	315111000001	1	315111000005	1	315111000005
30	Šroub – screw – tornillo	1	309281004006	1	309281006008	1	309281006008
31	Šroub – screw – tornillo	3	309787508015	3	309787512025	3	309787512025
				5	309787512025	5	309787512025
32	Šroub – screw – tornillo	3	309787508010	3	309787512015	3	309787512015
				5	309787512015	5	309787512015
33	Kulička – ball – bolita	3	324912025052	3	324914053252	3	324914053252
34	Šroub – screw – tornillo	1	412926012300	1	412926018900	1	412926034900
				1	412926027400	1	412926035100
				1	412926027600		
35	Rozpěrný kroužek – distance ring – anillo distanciador	1	412926013700	1	412926020900	1	412926036900
36	Kolík – pin – clavija	2	324931021053	2	311565003020	2	311565004020
37	Zadní ložisko – back bearing – cojinete trasero	1	412926013000	1	412926021000	1	412926037000

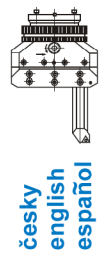

pozice position posición	Název dílu Part name Nombre de la parte	ks pcs pzs	Vhu 36 kód – code – código	ks pcs pzs	Vhu 56	ks pcs pzs	Vhu 125
					Vhu 80 Vhu 110		Vhu 160
			kód – code – código		kód – code – código		kód – code – código
38	Šroub – screw – tornillo	2	309231003008	2	309231004012	2	309231005016
39	Doraz – dog – tope			1	412926018100	1	412926018100
40	Kroužek – ring – anillo	2	412926013300	2	412926019300	2	412926035500
41	Šnek – worm – tornillo sin fin	1	412926011800	1	412926017600	1	412926034200
42	Šnekové kolo – worm wheel – rueda caracol	1	412926013500	1	412926018200	1	412926034500
43	Pero – parallel key – chaveta	1	412926015900	1	412926018500	1	412926018500
44	Matice – nut – tuerca	3	311120101040	3	311120101060	4	311120101060
45	Šroub – screw – tornillo	3	309283004016	3	309283006020	4	309283006020
46	Těleso – body – cuerpo	1	412926011100	1	412926016300	1	412926032800
				1	412926026500	1	41292603280001
				1	41292602650001		
47	Řídící kroužek – control ring – anillo de mando	1	412926011700	1	412926017400	1	412926034100
48	Kolík – pin – clavija	2	311565003010	2	311565008016	2	311565008016
49	Kulička – ball – bolita	2	324912020052	2	324914053252	2	324914053252
50	Tyč – bar – barra	1	412926005300	1	412926020700	1	412926036800
51	Koule – ball – bola			1	321461010650	1	321461010650
52	Šroub – screw – tornillo	1	309283005009	1	309281008008	1	309281008010
53	Pružina – spring – resorte	1	315111000002	1	315111000004	1	315111000004
54	Čep pojistky – pin – gorrón	1	412926004100	1	412926019900	1	412926019900
55	Kulička – ball – bolita	1	324912030052				
56	Šroub – screw – tornillo	1	412926014500				
57	Kolík – pin – clavija	1	412926014200				
58	Brzda – brake – freno	1	412926013200				
59	Čep – pin – gorrón	1	311560201608				
60	Šroub – screw – tornillo	6	309543005010	6	309543008012	6	309543008012
				6	309543006012		
61	Čep – pin – clavija	1	311560201608				
62	Zátka – plug – tapón	2	425111315423	2	425111315423	2	425111315423
63	Pojistný kroužek – circlip – anillo fiador	1	311733000320	1	311733000620	1	311733000800
64	Pero – parallel key – chaveta						
				4	412926028700	4	412926028700
65	Šroub – screw – tornillo						
				4	309231003008	4	309231003008
66	Kolík – pin – clavija	1	412926012700	1	412926022000	1	412926022000
67	Šroub – screw – tornillo	2	309787508010	2	309787512015	2	309787512015
68	Šroub – screw – tornillo			2	309787508010	2	309787508010

Vhu – ČÍSLA POZIC NÁHRADNÍCH DÍLŮ
Vhu – POSITION NUMBERS OF SPARE PARTS
Vhu – NÚMEROS DE RENGLONES DE REPUESTOS

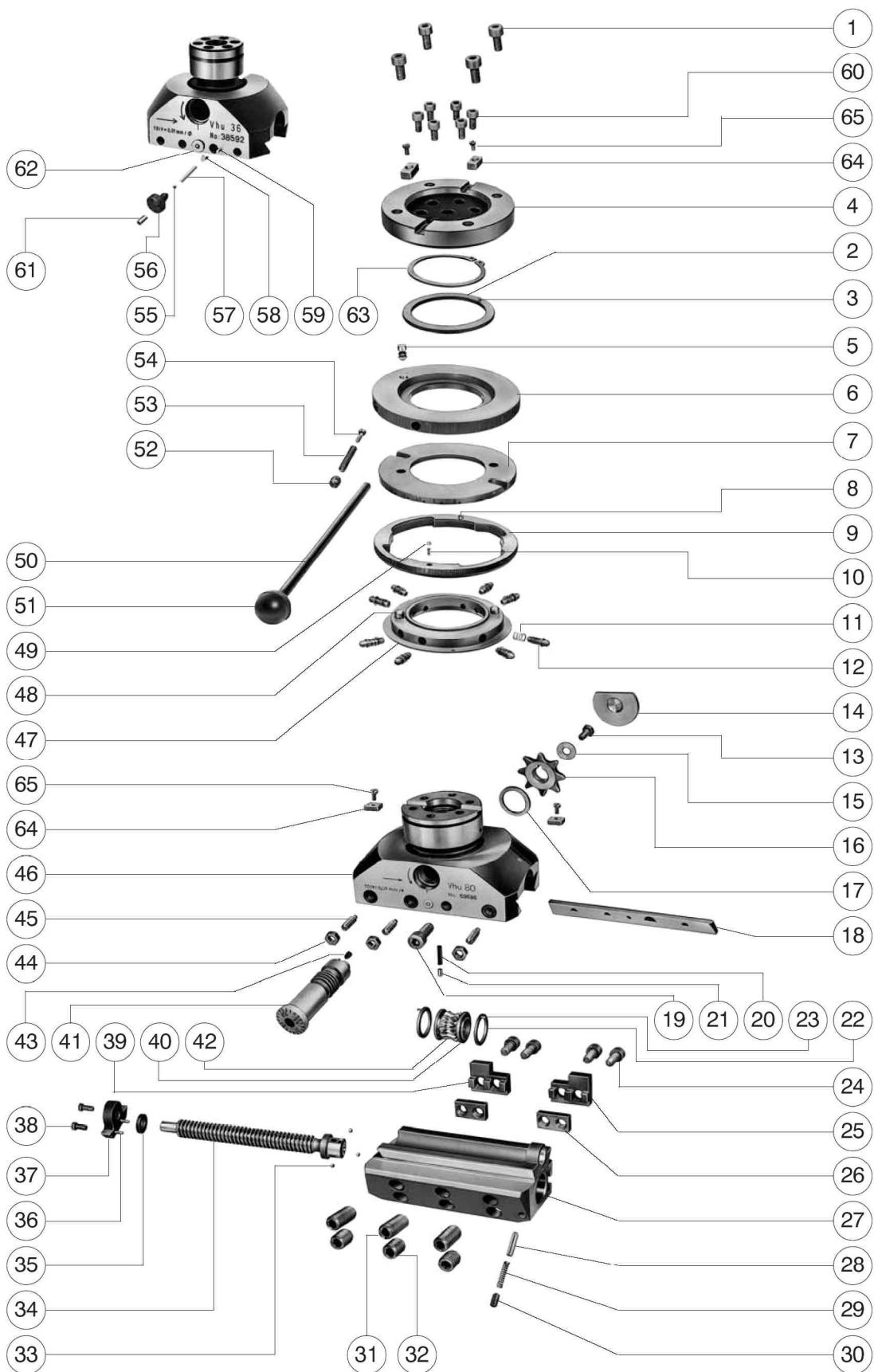

VYVRTÁVACÍ HLAVY UNIVERZÁLNÍ – Vhu

UNIVERSALE AUSBOHRKÖPFE – Vhu

УНИВЕРСАЛЬНЫЕ РАСТОЧНЫЕ ГОЛОВКИ – Vhu



LEGENDA – BESCHREIBUNG – ОБОЗНАЧЕНИЕ

- 5 – spojka – Kupplung – муфта
- 6 – brzdící kroužek – Bremsring – тормозное кольцо
- 27 – saně – Schlitten – салазки
- 34 – šroub – Schraube – винт
- 41 – šnek se stupnicí – Schnecke – червяк со шкалой
- 46 – těleso – Körper – корпус
- 50 – zastavovací tyč – Haltestab – остановочная штанга
- K – kuželová stopka – Kegelschaft – конический хвостовик

Vhu – jako vyvrtávací přístroj – značně rozšiřuje možnosti vyvrtávacích strojů, vrtaček, frézek apod. Hlavy se používají k přesnému vyvrtávání válcových otvorů a obrábění vnějších válcových ploch. Při použití samočinného posuvu saní lze hlavou obrábět čelní plochy otvorů, zapichovat a vyvrtávat kuželové plochy.

Posuv saní je seřiditelný ve 3 až 4 hodnotách a vypíná se při jejich vysunutí na nastavený doraz kolíčkovou spojkou. Posuv je odvozen od rotačního pohybu hlavy za předpokladu, že je zvolen jeden z posuvů, spojka je zasunuta a brzdící kroužek je zastaven zastavovací tyčí.

Šroub (34) slouží k rychlému přesunutí saní a šnek se stupnicí naopak k nastavování rozměru při přesném vyvrtávání (1 dílek = vysunutí saní o 0,05 mm).

Hlavy jsou dodávány včetně základního příslušenství v dřevěné kazetě. Upínací kuželová stopka je vyměnitelná a není součástí příslušenství, a proto je třeba ji objednávat zvlášť.

Hlavy Vhu 110/Vhu 160 jsou modifikací základního provedení Vhu 80/Vhu 125 - mají prodloužené saně včetně prodlouženého šroubu.

ZÁKLADNÍ TECHNICKÉ PARAMETRY – TECHNISCHE GRUNDDATEN – ОСНОВНЫЕ ТЕХНИЧЕСКИЕ ДАННЫЕ

	Vhu	36	56	80	110	125	160
Pohyb saní – Schlittenverschiebung – Перемещение салазок	max. [mm]	36	56	80	110	125	160
Obráběný průměr čela – Durchmesser der Stirnfläche – Обрабатываемый диаметр торцевой части	max. [mm]	230	320	380	430	610	690
Vyvrtávaný průměr – Ausbohrdurchmesser – Расточный диаметр	max. [mm]	225	360	410	450	650	720
Samočinný posuv – Automatischer Vorschub – Автоматическая подача	[mm.ot ⁻¹] [mm.u ⁻¹] [мм/об.]	0,02 0,04 0,06	0,05 – 0,10 – 0,15 – 0,20				
Ruční rychloposuv – Handschnellvorschub – Ручная скоростная подача	[mm.ot ⁻¹] [mm.u ⁻¹] [мм/об.]	3				4	
Přesnost nastavování – Einstellgenauigkeit – Точность настройки							
Průměr upínacích otvorů – Durchmesser der Spannbohrungen – Диаметр зажимных отверстий	dH8 [mm]	16	25			32	
Hmotnost hlavy/kazety – Gewicht des Kopfes/der Kassete – Масса головки/кассеты	[kg]	2,1/5,3	7,5/18,6	8,1/19,0	8,4/19,5	12,4/33,0	13,8/34,3
Kuželové stopky – Kegelschäfte – Конические хвостовики	VK	VK360	VK800, VK801			VK801	
Rozměry kazety – Kasseten Abmessungen – Размеры кассеты	[mm]	320 × 270 × 85	490 × 350 × 165			540 × 380 × 170	

ZÁKLADNÍ ROZMĚRY – HAUPTABMESSUNGEN – ОСНОВНЫЕ РАЗМЕРЫ

	Kód – Code – Код	A	B	C	D	E
Vhu 36	201.146 (model C)	78	78	28	53	100
Vhu 56	201.153 (model C)	115	115	36	80	134
Vhu 80	201.160 (model C)	140	140	36	80	134
Vhu 110	201.177 (model C)	165	140	36	80	134
Vhu 125	201.184 (model C)	190	190	42	92	151
Vhu 160	201.191 (model C)	225	190	42	92	159

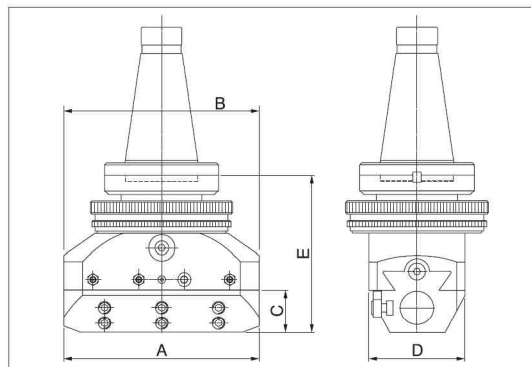

Vhu – als Ausbohrgerät - vergrößert erheblich die Möglichkeiten der Bohrwerken, Bohr- und Fräsmaschinen u. a. Die Köpfe werden zum präzisen Ausbohren der zylindrischen Bohrungen und Bearbeiten der zylindrischen Aussenflächen gebraucht. Der Kopf kann durch die Verwendung des automatischen Vorschubs stirnsenken (plandrehen), der Kegelflächen einstechen und ausbohren. Der Schlitten-vorschub ist in 3 oder 4 Stufen einstellbar und schaltet sich automatisch am eingestellten Anschlag durch die Stiftkupplung aus. Der Vorschub ist aus der Drehbewegung des Kopfes hergeleitet unter der Voraussetzung, dass eine von der Vorschubstufen gewählt, der Stift der Stiftkupplung eingeschoben und der Bremsring durch den Haltestab abgestellt ist.

Die Schraube (34) dient zum schnellen Verschieben des Schlittens und die Schnecke mit der Skala dient im Gegenteil zum genauen Einstellen der Abmessung. (1 Teilstrich = Schlittenverschiebung 0,005 mm) Die Köpfe werden mit dem Grundzubehör in den Holzkassetten geliefert. Der Kegelschaft ist austauschbar und ist nicht im Grundzubehör eingeschlossen und es ist notwendig diesen extra zu bestellen.

Der Kopf Vhu 110 / Vhu 160 ist eine Modifikation der Grundausführung Vhu 80 / Vhu 125 - er hat den verlängerten Schlitten und die verlängerte Schraube.

Vhu – в качестве расточного прибора – в значительной степени расширяет возможности применения расточных, сверлильных, фрезерных станков и т.п. Данные головки применяются для точного сверления цилиндрических отверстий и для обработки внешних цилиндрических поверхностей. При использовании автоматической подачи салазок с помощью головки можно проводить обработку торцевой поверхности отверстий, проточку канавок и расточку конических поверхностей.

Подача салазок регулируется в пределах 3–4 значений и выключается при их выдвигении до отрегулированного упора с помощью штифтовой муфты. Подача производится от вращающегося движения головки при условии выбора одной из ступеней подачи, муфта задвинута и тормозное кольцо остановлено при помощи стопорного стержня.

Болт (34) применяется для скоростного перемещения салазок и червяк со шкалой наоборот используется для регулировки размера при точной расточке (одно деление равно выдвигению салазок на 0,05 мм).

Головки поставляются вместе с основными принадлежностями в деревянном футляре. Зажимной конический хвостовик является взаимозаменяемым и не входит в объем принадлежностей, в следствие чего его следует заказывать отдельно.

Головки Vhu 110 /Vhu 160 представляют собой модификацию стандартного исполнения Vhu 80/Vhu 125-оснащены удлиненными салазками, включая удлиненный болт.



Vhu 36

Vhu 56

Vhu 80

Vhu 125

ZÁKLADNÍ STROJNÍ OPERACE PROVÁDĚNÉ POMOCÍ Vhu

ELEMENTARE ARBEITSGÄNGE, DIE MITTELS Vhu REALISIERBAR SIND

ОСНОВНЫЕ СТАНОЧНЫЕ ОПЕРАЦИИ ВЫПОЛНЕННЫЕ ГОЛОВКАМИ Vhu

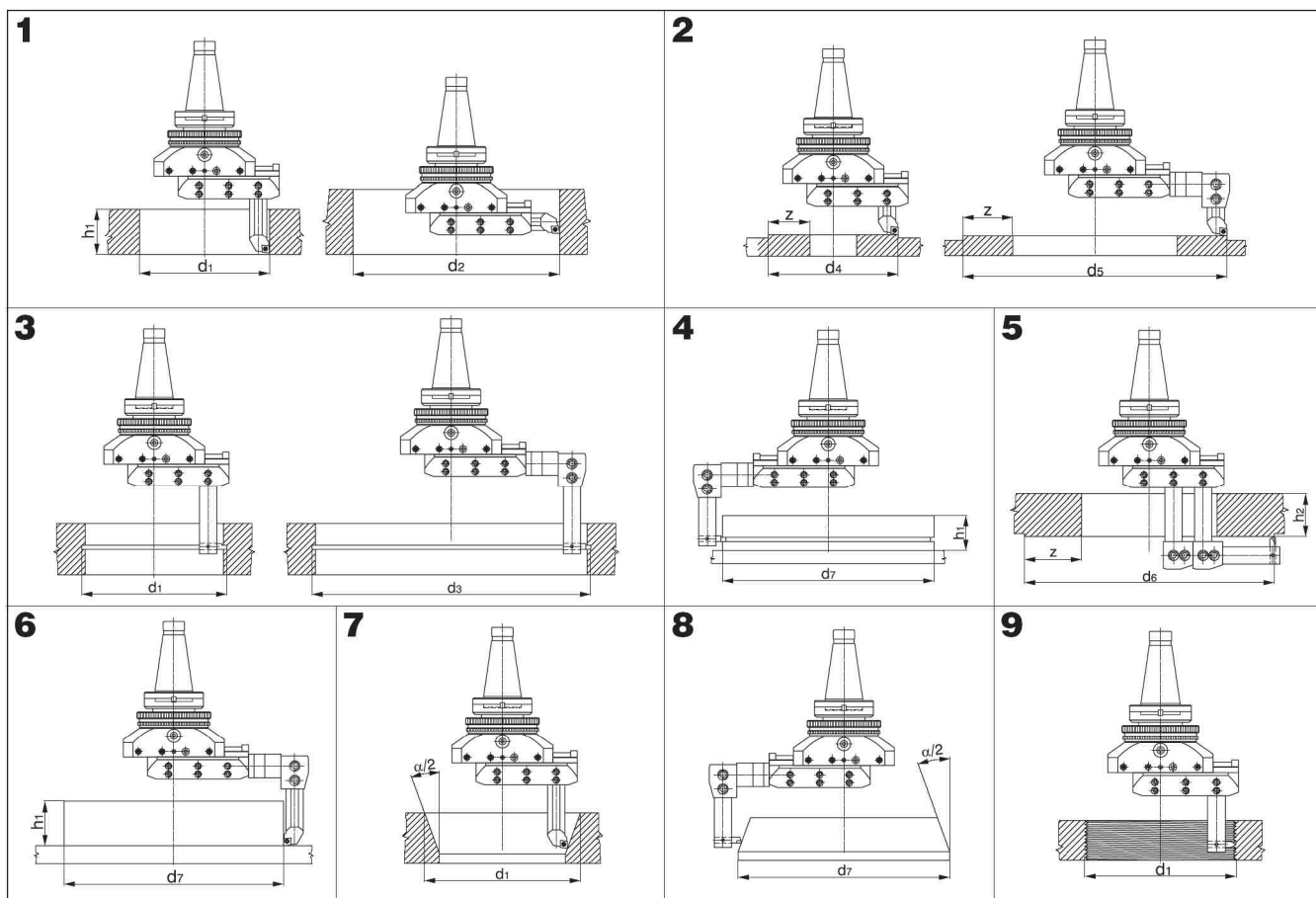

	Z _{max} [mm]	d _{max} [mm]							h _{max} [mm]	
		d ₁	d ₂	d ₃	d ₄	d ₅	d ₆	d ₇	h ₁	h ₂
Vhu 36	36	92	160	225	88	230	200	200	45	80
Vhu 56	56	170	250	360	210	320	300	280	125	85
Vhu 80	80	210	300	410	180	380	380	320	125	110
Vhu 110	110	270	340	450	240	430	430	370	125	110
Vhu 125	125	280	390	650	245	610	600	530	205	115
Vhu 160	160	350	480	720	340	690	690	610	205	115

POPIS – BESCHREIBUNG – ОПИСАНИЕ

1	2	3	4	5	6	7	8	9
Vyvtávání otvoru	Zarovnávání předního čela	Vnitřní zapichování	Vnější zapichování	Zarovnávání zadního čela	Obrábění vnější válcové plochy	Vyvtávání kuželového otvoru	Obrábění vnější kuželové plochy	Řezání závitů
Ausbohren	Stirnsenken, Plandrehen	Inneneinstechen	Ausseneinstechen	Stirnsenken von hinten	Bearbeiten der zylindrischen Aussenflächen	Kegelausbohren	Bearbeiten der kegeligen Aussenflächen	Gewindeschneiden
Расточка отверстий	Цекование	Протачивание внутренней канавки	Протачивание внешней канавки	Цекование задних опорных поверхностей	Обработка внешних цилиндрических поверхностей	Расточка конических отверстий	Обработка внешних конических поверхностей	Нарезка резьбы

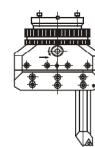

česky
deutsch
русский

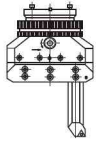

deutsch

VERKAUFGARNITUREN – ZUBEHÖRSPEZIFIKATION					TABELLEN- NUMMER
A	B	C	D	T	
Ausbohrkopf Vhu ohne Zubehör	Ausbohrkopf Vhu mit Grundzubehör	Vhu mit Komplettzubehör ohne WSP			
					201
					202
					203
					204
					205
					206
					207
					208
					301
					302
					303
					304
					305
					305
					306
					306
					307
					308
					309
				WSP	
KARTON- VERPACKUNG	HOLZKASSETTE	HOLZKASSETTE	HOLZKASSETTE	VERPACKUNG	HOLZKASSETTE

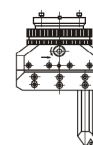

deutsch

TABELLEN- NUMMER	ZUBEHÖRLISTE	Vhu						BEZEICHNUNGSKODE DER GARNITUR
		x - Zeilennummer der zugehörigen Tabelle xx - Stückzahl in der Garnitur						
		36	56	80	110	125	160	
201	Halter mit Schraube x xx	1 1 St.	2 1 St.	3 1 St.	4 1 St.	5 1 St.	6 1 St.	A Ausbohrkopf in Kartonverpackung Vhu 36 - A / 201 207 Vhu 56 - A / 201 214 Vhu 80 - A / 201 221 Vhu 110 - A / 201 238 Vhu 125 - A / 201 245 Vhu 160 - A / 201 252
202	Halter		1 2 St.	2 2 St.	2 2 St.	3 2 St.	3 2 St.	
203	Satz der Distanzbuchsen	1 1 Satz	2 1 Satz	2 1 Satz	2 1 Satz	3 1 Satz	3 1 Satz	
204	Reduzierhülse	1 1 St.	2 1 St.	2 1 St.	2 1 St.	4 1 St.	4 1 St.	
205	Haltestab	1 1 St.	2 1 St.	2 1 St.	2 1 St.	3 1 St.	3 1 St.	
206	Schraubendreher mit Quergriff	1 1 St.	1 1 St.	1 1 St.	1 1 St.	1 1 St.	1 1 St.	B Ausbohrkopf, Grundzubehör, Holzkassette Vhu 36 - B / 201 269 Vhu 56 - B / 201 276 Vhu 80 - B / 201 283 Vhu 110 - B / 201 290 Vhu 125 - B / 201 306 Vhu 160 - B / 201 313
207	Schraubendrehereinsatz	1 1 St.	1+2 1 St.	1+2 1 St.	1+2 1 St.	1+2 1 St.	1+2 1 St.	
208	Schraubendreher	1 1 St.	1+2 1 St.	1+2 1 St.	1+2 1 St.	1+2 1 St.	1+2 1 St.	
301	Ausdrehmeissel	1+2 1 St.	2 1 St.	2 1 St.	2 1 St.	2 1 St.	2 1 St.	
302	Wendeplattenhalter VBD STFOR 11	1 1 St.	1 1 St.	1 1 St.	1 1 St.	1 1 St.	1 1 St.	
303	Wendeplattenhalter VBD STFCR 11	1 1 St.	2 1 St.	2 1 St.	2 1 St.	3 1 St.	3 1 St.	C Ausbohrkopf, Grundzubehör, Meisselzubehör, Holzkassette Vhu 36 - C / 201 146 Vhu 56 - C / 201 153 Vhu 80 - C / 201 160 Vhu 110 - C / 201 177 Vhu 125 - C / 201 184 Vhu 160 - C / 201 191
304	Wendeplattenhalter VBD STKCR 11	1 1 St.	2 1 St.	2 1 St.	2 1 St.	3 1 St.	3 1 St.	
305	Wendeplattenhalter VBD SCACL	2 1 St.	4 1 St.	4 1 St.	4 1 St.	6 1 St.	6 1 St.	
305	Wendeplattenhalter VBD SCACR	1 1 St.	3 1 St.	3 1 St.	3 1 St.	5 1 St.	5 1 St.	
306	Wendeplattenhalter VBD SCBCL	2 1 St.	4 1 St.	4 1 St.	4 1 St.	6 1 St.	6 1 St.	
306	Wendeplattenhalter VBD SCBCR	1 1 St.	3 1 St.	3 1 St.	3 1 St.	5 1 St.	5 1 St.	D Ausbohrkopf, Grund- und Meissel- zubehör, Wendeplatten, Holzkassette Vhu 36 - D / 201 085 Vhu 56 - D / 201 092 Vhu 80 - D / 201 108 Vhu 110 - D / 201 115 Vhu 125 - D / 201 122 Vhu 160 - D / 201 139
307	Halterstange	1 1 St.	2+3 1 St.	2+3 1 St.	2+3 1 St.	4+5 1 St.	4+5 1 St.	
308	Wendeplattenhalter	1 1 St.	2 1 St.	2 1 St.	2 1 St.	3 1 St.	3 1 St.	
309	Wendeplattenhalter Gewinde	1 1 St.	2 1 St.	2 1 St.	2 1 St.	3 1 St.	3 1 St.	
	WOHLHAUPTER Form 161 WTI 12 097512 1a*	4 St.	4 St.	4 St.	4 St.	4 St.	4 St.	
	CCMT 060204E CCMT 09T304E UM 8016	4 St.	4 St.	4 St.	4 St.	4 St.	4 St.	

1b* - TCMT 110202 E UM 8016
 (* Man liefert 1b wenn 1a nicht beansprucht.)

Das Meisselzubehör wird entweder in Garnituren C oder D geliefert, die Halter werden ohne Wendeschneidplatten geliefert. Man kann die Halter einzeln nach der Bezeichnung und Kodenummer bestellen.

Vhu - MEISSELZUBEHÖR

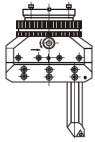

Im Rahmen der Forderungen nach Verbesserung der Qualität, Produktivität und der Standzeit beim Ausbohren hat unsere Firma eine Innovation des Meisselzubehörs für Ausbohren durchgeführt.

deutsch

Was wurde ersetzt:

HSS-Werkzeuge, Bohrstangen, Werkzeuge mit eingelöteten Schneidplatten.

Es wurde ersetzt mit:

- 1) Ausdrehmeissel 301 mit der eingelöteten, beschichteten Schneidplatte mit der positiven Schneidengeometrie sind für Ausbohren der Bohrungen von \varnothing 6 mm bestimmt. Sehr kleine Spandicken bis 0,05 mm mit der hohen Qualität der gefertigten Fläche sind möglich.
- 2) Wendeplattenhalter 302, 303 und 304 sind mit dreieckigen Platten mit 3 Schneiden und kleinen Eckenradius bestückt. die das Feinbohren mit sehr kleinen Spandicken (0,05 mm) ermöglichen. Es ist auch möglich die geschliffene Wohlhaupter-Platten, Form 161 mit der hochpositiven Geometrie für extrem kleine Spandicken bis 0,02 mm mit Garantie der hohen Qualität der gefertigten Fläche verwenden.
- 3) Wendeplattenhalter 305 und 306 ersetzen die geraden Bohrmeissel, die für Stirnsenken und Ausbohren der grossen Bohrungen bestimmt sind – das Werkzeug wird in der Querbohrung der Schlitten gespannt.
- 4) Wendeplattenhalter 308 und 309 werden an die Halterstange 307 gespannt. Der Wendeplattenhalter 308 ist für Stirnsenken von hinten bestimmt, der Wendeplattenhalter Gewinde – Einstich 309 ermöglicht Gewindecneiden oder Einstechen in Bohrungen oder an den Aussenflächen.

Verwendungsvorteile dieser Werkzeuge:

- längere Standzeit
- Möglichkeit der produktiven und präzisen Bearbeitung auch bei mangelhafter oder keiner Kühlung
- Wendeschneidplatten brauchen kein Nachschärfen und ermöglichen den schnellen Wechsel der Schneidkante
- Wendeschneidplatten der Firma Wohlhaupter gewähren sehr hohe Qualität des Ausbohrens
- Es ist möglich die Bohrungen von grösseren Durchmessern (min. 50 mm) mit optimalen Schnittbedingungen und höher Produktivität als früher bearbeiten

Information:

- Die neue Bestellmethode und Lieferung der Ausbohrköpfe Vhu hinsichtlich der Innovation des Meisselzubehörs und entsprechenden Preisen der Garnitur D wird seit den 1. Januar 2004 realisiert.
- Flexibilität der neuen Bestellmethode ermöglicht das Zusammenstellen der Bestellung nach den Forderungen der Kunden von irgendeinen Garnituren oder Aussuchen der einzelnen Posten des Meisselzubehörs.
- Die Wendeplattenhalter werden ohne WSP geliefert.
- Die Kegelschäfte sind nicht in den Ausbohrköpfen eingeschlossen.
- Die "T" Ausführung entspricht den Preisen und ursprünglicher Anwendung der Zusammenstellung.

GRUNDZUBEHÖR

201 HALTER MIT SCHRAUBE

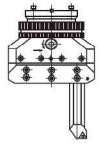
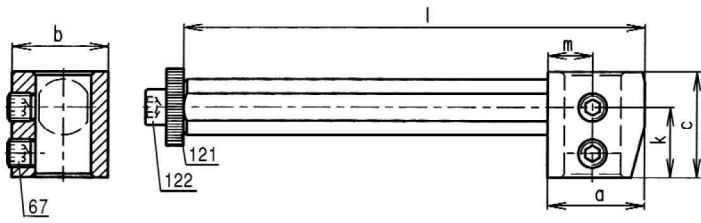

deutsch

	Kode	Bezeichnung	Abmessungen (mm)							kg	67 Schraube	122 Schraube	121 Scheibe	gehört zu
			a	b	c	d	k	l	m					
1	203 706	VDS 16 - 132	27	27	30	16	20	132	13	0,28	M8x1 - 10	M6-25	6	Vhu 36
2	203 591	VDS 25 - 195	45	46	46	25	33	195	22,5	0,95	M12x1 - 15	M12-40	12	Vhu 56
3	203 614	VDS 25 - 220	45	46	46	25	33	220	22,5	1,1	M12x1 - 15	M12-40	12	Vhu 80
4	203 638	VDS 25 - 244	45	46	46	25	33	244	22,5	1,18	M12x1 - 15	M12-40	12	Vhu 110
5	203 669	VDS 32 - 350	50	56	56	32	39	350	22,5	2,5	M12x1 - 15	M12-40	12	Vhu 125
6	203 683	VDS 32 - 383	50	56	56	32	39	383	22,5	2,75	M12x1 - 15	M12-40	12	Vhu 160

202 HALTER

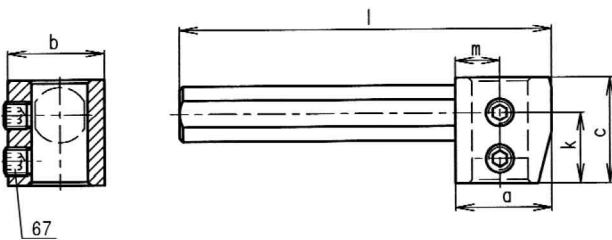

	Kode	Bezeichnung	Abmessungen (mm)							kg	67 Schraube	gehört zu
			a	b	c	d	k	l	m			
1	203 607	VDS 25 - 160	45	46	46	25	33	160	22,5	0,9	M12x1 - 15	Vhu 56
2	203 621	VDS 25 - 185	45	46	46	25	33	185	22,5	1,0	M12x1 - 15	Vhu 80, Vhu 110
3	203 676	VDS 32 - 210	50	56	56	32	39	210	22,5	1,7	M12x1 - 15	Vhu 125, Vhu 160

203 SATZ DER DISTANZBUCHSEN

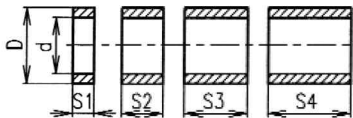

	Kode	Bezeichnung	St./Garnitur	Abmessungen (mm)		
				d	D	S1/S2/S3/S4
1	301 006	SATZ DER DISTANZBUCHSEN 16	3	16,2	22	6/12/18
2	301 013	SATZ DER DISTANZBUCHSEN 25	3	25,2	35	18/16/25
3	301 020	SATZ DER DISTANZBUCHSEN 32	4	32,3	44	12/24/36/50

204 REDUZIERHÜLSE

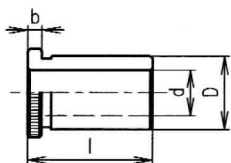

	Kode	d x D	l/b	kg	gehört zu
1	301 037	10 x 16	30/5	0,03	Vhu 36
2	301 044	16 x 25	42/6	0,09	Vhu 56, 80, 110
3	301 051	20 x 25	42/6	0,06	Vhu 56, 80, 110
4	301 068	16 x 32	56/6	0,25	Vhu 125, 160
5	301 075	25 x 32	56/6	0,18	Vhu 125, 160
6	301 082	20 x 32	56/6	0,20	Vhu 125, 160

● Standard ■ nach Nachfrage

MEISSELZUBEHÖR



deutsch

301 AUSDREHMEISSEL		FCRK 10 - Ni HF							
	Kode	Bezeichnung	Abmessungen (mm)				kg	ab	
			D	d	L	a		∅	
1	203 201	VPS 16 - 062 FCRK 10-Ni HF 658 00550	16	5,5	60	30	0,05	6	
2	203 317	VPS 16 - 073 FCRK 10-Ni HF 658 00550	16	9,5	73	43	0,06	10	

302 WENDEPLATTENHALTER WSP		STFCR 11							
	Kode	Bezeichnung	Abmessungen (mm)				kg	ab	
			D	b	L	a		∅	
1	203 324	DDS 16 - 080 STFOR 11	16	5,9	80	53	0,09	12	
Kode: 203 874 Kode: 203 829		Wohlhaupter Form 161 WTI 12 097512 Pramet TCMT 110202 E - UM 8016	US 2505				T 7		

303 WENDEPLATTENHALTER WSP		STFCR 11							
	Kode	Bezeichnung	Abmessungen (mm)			kg	ab		
			D	b	L		∅		
1	203 331	DDS 16 - 090 STFCR 11	16	11	90	0,12	20		
2	203 416	DDS 25 - 150 STFCR 11	25	17	150	0,51	32		
3	203 492	DDS 32 - 180 STFCR 11	32	22	180	0,97	38		
Kode: 203 874 Kode: 203 829		Wohlhaupter Form 161 WTI 12 097512 Pramet TCMT 110202 E - UM 8016	US 2505				T 7		

304 WENDEPLATTENHALTER WSP		STKCR 11							
	Kode	Bezeichnung	Abmessungen (mm)			kg	ab		
			D	b	L		∅		
1	203 348	DDS 16 - 090 STKCR 11	16	11	90	0,12	20		
2	203 423	DDS 25 - 150 STKCR 11	25	17	150	0,51	32		
3	203 508	DDS 32 - 180 STKCR 11	32	22	180	0,97	38		
Kode: 203 874 Kode: 203 829		Wohlhaupter Form 161 WTI 12 097512 Pramet TCMT 110202 E - UM 8016	US 2505				T 7		

305 WENDEPLATTENHALTER WSP		SCACR/L							
	Kode	Bezeichnung	Abmessungen (mm)			kg	R-recht L-link		
			D	L	f				
1	203 355	DDS 16 - 050 SCACR 06	16	50	9	0,06	R		
2	203 386	DDS 16 - 050 SCACL 06	16	50	9	0,06	L		
3	203 447	DDS 25 - 080 SCACR 09	25	80	14	0,25	R		
4	203 461	DDS 25 - 080 SCACL 09	25	80	14	0,25	L		
5	203 522	DDS 32 - 100 SCACR 09	32	100	17	0,53	R		
6	203 546	DDS 32 - 100 SCACL 09	32	100	17	0,53	L		
Kode: 203 829 Kode: 203 843		DDS 16: CCMT 0602 4E-UM8016 DDS 25, DDS 32: CCMT 09T304E-UM8016	DDS 16: US 2505 DDS 25, 32: US-13				T 7 T15		

MEISSELZUBEHÖR

306 WENDEPLATTENHALTER WSP

SCBCR/L

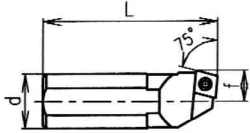

	Kode	Bezeichnung	Abmessungen (mm)			kg	R-recht L-link
			D	L	f		
1	203 362	DDS 16 - 050 SCBCR 06	16	50	9	0,06	R
2	203 379	DDS 16 - 050 SCBCL 06	16	50	9	0,06	L
3	203 430	DDS 25 - 080 SCBCR 09	25	80	14	0,25	R
4	203 454	DDS 25 - 080 SCBCL 09	25	80	14	0,25	L
5	203 515	DDS 32 - 100 SCBCR 09	32	100	17	0,53	R
6	203 539	DDS 32 - 100 SCBCL 09	32	100	17	0,53	L



Kode: 203 829
Kode: 203 843

DDS 16: CCMT 060204E-UM8016
DDS 25, DDS 32: CCMT 09T304E UM8016



DDS 16: US 2505
DDS 25, 32: US-13



T 7
T15

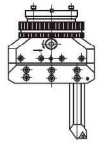

deutsch

307 HALTERSTANGE

VTS

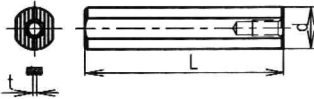

	Kode	Bezeichnung	Abmessungen (mm)			kg	gehört zu
			D	L	t		
1	203 690	VTS 16 - 075 - 1,5	16	75	1,5	0,11	VHS 16, VHZ 16
2	203 584	VTS 25 - 085 - 1,5	25	85	1,5	0,31	VHS 25, VHZ 25
3	203 577	VTS 25 - 145 - 1,5	25	145	1,5	0,51	VHS 25, VHZ 25
4	203 652	VTS 32 - 135 - 1,5	32	135	1,5	0,78	VHS 32, VHZ 32
5	203 645	VTS 32 - 235 - 1,5	32	235	1,5	1,40	VHS 32, VHZ 32

Ersatzteile



M6x20 07150



Sechskantschraubendreher 4

308 WENDEPLATTENHALTER

STZCL 11

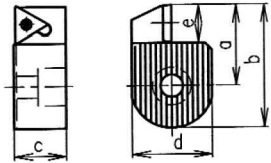

	Kode	Bezeichnung	Abmessungen (mm)					kg
			a	b	c	d	e	
1	203 393	VHS 16 - 1,5 STZCL 11	14	27	15	19	11	0,02
2	203 478	VHS 25 - 1,5 STZCL 11	23	35	15	23	11	0,06
3	203 553	VHS 32 - 1,5 STZCL 11	29	43	15	27	11	0,09



Kode: 203 289

Pramet TCMT 110202 E - UM 8016



M2,5x7
US 2505



T 7

309 WENDEPLATTENHALTER GEWINDE - EINSTICH

VHZ

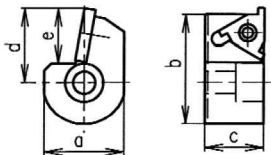

	Kode	Bezeichnung	Abmessungen (mm)					kg
			a	b	c	d	e	
1	203 409	VHZ 16 - 1,5 ST - R16	14	27	17	21,5	14,5	0,02
2	203 485	VHZ 25 - 1,5 ST - R16	23	31,5	17	19,5	14,5	0,05
3	203 560	VHZ 32 - 1,5 ST - R16	29	36	17	21,5	14,5	0,08



TN 16 NR - *** ZZ
*** A = Einstichbreite
A: 1,10; 1,60; 2,15;
1,13; 1,85; 2,65



TN 16 NR *** M - Metrisches Gewinde
*** s = Gewindesteigung
s: 0,50; 1,00; 1,50; 2,00; 3,00;
0,75; 1,25; 1,75; 2,50



US 53



T 15

BEZEICHNUNGSKODE DES ZUBEHÖRS

Bezeichnungskode der Wendepplattenhalter, Bohrstangen

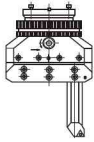

deutsch

DD	Bohrdrehmeissel - Wendepplattenhalter	Spanndurchmesser D (mm)	Länge des Bohrdrehmeissels (Halters) L (mm)	Befestigungsart der Platten ISO
VP	Bohrdrehmeissel mit aufgelöteter Schneidplatte			
DV	Ausrückwendeplattenhalter	D1 - Minimaldurchmesser - für Ausrückwendeplattenhalter (DV)	D2 - Maximaldurchmesser - für Ausrückwendeplattenhalter (DV)	
VD	Halter			
VT	Bohrstangen, Halterstangen	Spanndurchmesser D (mm)	Länge des Bohrdrehmeissels (Halters) L (mm)	
VH	Wendepplattenhalter für Halterstangendurchmesser D			
				Teilung der Führungsrillen t (*,*) (mm)
				- ohne Befestigung

D D S 1 6 - 0 8 7 S C G C L 0 9 X X X X

S	ohne Innenkühlung
A	mit Innenkühlung
Z	Gewindewendepplattenhalter

Plattenform - ISO	
S	
C	
D	
K	
V	
T	
R	
W	
L	
X	Spezial
-	ohne Befestigung

Meisselform - Einstellwinkel - ISO											
A		B		C		D		D		D	
	90°		75°		90°		45°				
E		F		G		H		J			
	60°		90°		90°		107°30'		93°		
K		L		M		N		P			
	75°		95°		50°		62°30'		117°30'		
Q		R		S		S		T			
	107°30'		75°		45°				60°		
U		V		W		X	Spezial	Y			
	93°		72°30'		60°				85°		
Z		- ohne Befestigung									

Ergänzungsangabe - fakultativ - empfohlen

Freiwinkel - ISO	WOHLHAUPTER
αn	
N	$\alpha n=0^\circ$
C	$\alpha n=7^\circ$
P	$\alpha n=11^\circ$
O	$\alpha n=10^\circ$

Schneidrichtung - ISO	WOHLHAUPTER
R	
L	
N	
	Rechts-schneidend Links-schneidend Neutral

Plattengröße - ISO	WOHLHAUPTER										
	Form	S	C	D	V	K	W	T	R	W	T
d [mm]											
4,00										6.9	6.9
4,90											8.5
6,00								06			
6,35			06	07	11			11			
8,00											
9,525	09	09	11	16	19	06	16				
10,00										10	
12,00										12	
12,70	12	12					08	22	12		
15,875	15	16	15					27	15		
16,00									16		
19,05	19	19							19		
20,00									20		
25,00									25		
25,40	25	25							25		

pozice Position позиция	Název dílu Benennung des Teiles Название детали	ks Stück шт.	Vhu 36 kód – Code – код	ks Stück шт.	Vhu 56	ks Stück шт.	Vhu 125
					Vhu 80		Vhu 160
					Vhu 110		
1	Šroub – Schraube – Винт	4	309543005010	4	309543008016	4	309543008016
2	Kroužek – Ring – Кольцо	1	412926001400	1	412926016700	1	412926033400
3	Kolík – Stift – Штифт	1	412926001500	1	311565002008	1	311565002008
4	Spojovací příruba – Verbindungsflansch – Крепежный фланец	1	412926008100	1	412926028800	1	412926039600
5	Pojistka – Sicherung – Предохранитель	1	412926004200	1	412926016900	1	412926016900
6	Brzdící kroužek – Bremsring – Тормозное кольцо	1	412926001500	1	412926016800	1	412926033500
7	Kroužek – Ring – Кольцо	1	412926011500	1	412926017000	1	412926033600
8	Kolík – Stift – Штифт	2	311565002008	2	311565004010	2	311565004010
9	Ovládací kroužek – Bedienungsring – Кольцо управления	1	412926001800	1	412926017200	1	412926033800
10	Pružina – Feder – Пружина	2	315110013330	1	315110003540	1	315110003540
11	Pružina – Feder – Пружина	6	315110003500	8	315110000000	8	315110000000
12	Kolík – Stift – Штифт	6	412926002100	8	412926017300	8	412926017300
13	Šroub – Schraube – Винт	1	309303004008	1	412926021900	1	412926021900
14	Víčko – Deckel – Крышка	1	412926011400	1	412926028300	1	412926031800
15	Podložka – Scheibe – Шайба	1	412926015800	1	412926021400	1	412926021400
16	Rohatka – Sperrad – Храповик	1	412926012800	1	412926018600	1	412926034800
17	Kroužek – Ring – Кольцо	1	412926013100	1	412926018800	1	412926018800
18	Pravítko – Leiste – Линейка	1	412926012000	1	412926017800	1	412926034400
				1	412926027300		
				1	412926027300		
19	Šroub – Schraube – Винт			1	309543008020	1	309543008020
20	Pružina – Feder – Пружина			1	315111000003	1	315111000003
21	Brzda – Bremse – Тормоз			1	412926018700	1	412926032200
22	Kroužek – Ring – Кольцо	2	412926013400	2	412926019200	2	412926035400
23	Kolík – Stift – Штифт	2	311565001605	2	311565002008	2	311565002008
24	Šroub – Schraube – Винт	2	309543005010	4	309543008016	4	309543008016
25	Doraz – Anschlag – Упор	2	412926004400	1	412926018000	1	412926018000
26	Vložka – Einlage – Вставка	2	412926005500	2	412926017900	2	412926017900
27	Saně sestava – Schlitten – Салазки в сборе	1	412926012100	1	412926016500	1	412926033000
				1	412926027000	1	412926033200
				1	412926027200		
28	Západka – Klinke – Собачка	1	412926014700	1	412926019100	1	412926035300
29	Pružina – Feder – Пружина	1	315111000001	1	315111000005	1	315111000005
30	Šroub – Schraube – Винт	1	309281004006	1	309281006008	1	309281006008
31	Šroub – Schraube – Винт	3	309787508015	3	309787512025	3	309787512025
				5	309787512025	5	309787512025
32	Šroub – Schraube – Винт	3	309787508010	3	309787512015	3	309787512015
				5	309787512015	5	309787512015
33	Kulička – Kugel – Шарик	3	324912025052	3	324914053252	3	324914053252
34	Šroub – Schraube – Винт	1	412926012300	1	412926018900	1	412926034900
				1	412926027400	1	412926035100
				1	412926027600		
35	Rozpěrný kroužek – Zwischenring – Распорное кольцо	1	412926013700	1	412926020900	1	412926036900
36	Kolík – Stift – Штифт	2	324931021053	2	311565003020	2	311565004020
37	Zadní ložisko – Hinterlager – Подшипник задний	1	412926013000	1	412926021000	1	412926037000

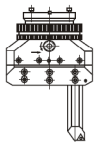

česky
deutsch
но-русски

pozice Position позиция	Název dílu Benennung des Teiles Название детали	ks Stück шт.	Vhu 36 kód – Code – код	ks Stück шт.	Vhu 56	ks Stück шт.	Vhu 125
					Vhu 80 Vhu 110		Vhu 160
			kód – Code – код		kód – Code – код		kód – Code – код
38	Šroub – Schraube – Винт	2	309231003008	2	309231004012	2	309231005016
39	Doraz – Anschlag – Упор			1	412926018100	1	412926018100
40	Kroužek – Ring – Кольцо	2	412926013300	2	412926019300	2	412926035500
41	Šnek – Schnecke – червяк	1	412926011800	1	412926017600	1	412926034200
42	Šnekové kolo – Schneckenrad – червячное колесо	1	412926013500	1	412926018200	1	412926034500
43	Pero – Feder – Шпонка	1	412926015900	1	412926018500	1	412926018500
44	Maticе – Mutter – Гайка	3	311120101040	3	311120101060	4	311120101060
45	Šroub – Schraube – Винт	3	309283004016	3	309283006020	4	309283006020
46	Těleso – Körper – Корпус	1	412926011100	1	412926016300	1	412926032800
				1	412926026500	1	41292603280001
				1	41292602650001		
47	Řídící kroužek – Steuerring – Управляющее кольцо	1	412926011700	1	412926017400	1	412926034100
48	Kolík – Stift – Штифт	2	311565003010	2	311565008016	2	311565008016
49	Kulička – Kugel – Шарик	2	324912020052	2	324914053252	2	324914053252
50	Tuč – Stab – Штанга	1	412926005300	1	412926020700	1	412926036800
51	Koule – Kugel – Шарик			1	321461010650	1	321461010650
52	Šroub – Schraube – Винт	1	309283005009	1	309281008008	1	309281008010
53	Pružina – Feder – Пружина	1	315111000002	1	315111000004	1	315111000004
54	Čep pojistky – Stift – Цапфа предохранителя	1	412926004100	1	412926019900	1	412926019900
55	Kulička – Kugel – Шарик	1	324912030052				
56	Šroub – Schraube – Винт	1	412926014500				
57	Kolík – Stift – Штифт	1	412926014200				
58	Brzda – Bremse – Тормоз	1	412926013200				
59	Čep – Stift – Цапфа	1	311560201608				
60	Šroub – Schraube – Винт	6	309543005010	6	309543008012	6	309543008012
				6	309543006012		
61	Čep – Stift – Цапфа	1	311560201608				
62	Zátka – Stopfen – Пробка	2	425111315423	2	425111315423	2	425111315423
63	Pojistný kroužek – Sicherungsring – Стопорное кольцо	1	311733000320	1	311733000620	1	311733000800
64	Pero – Feder – Шпонка						
				4	412926028700	4	412926028700
65	Šroub – Schraube – Винт						
				4	309231003008	4	309231003008
66	Kolík – Stift – Штифт	1	412926012700	1	412926022000	1	412926022000
67	Šroub – Schraube – Винт	2	309787508010	2	309787512015	2	309787512015
68	Šroub – Schraube – Винт			2	309787508010	2	309787508010

Vhu – ČÍSLA POZIC NÁHRADNÍCH DÍLŮ
 Vhu – POSITIONSNUMMERN VON ERSATZTEILEN
 Vhu – НОМЕРА ПОЗИЦИЙ ЗАПАСНЫХ ЧАСТЕЙ

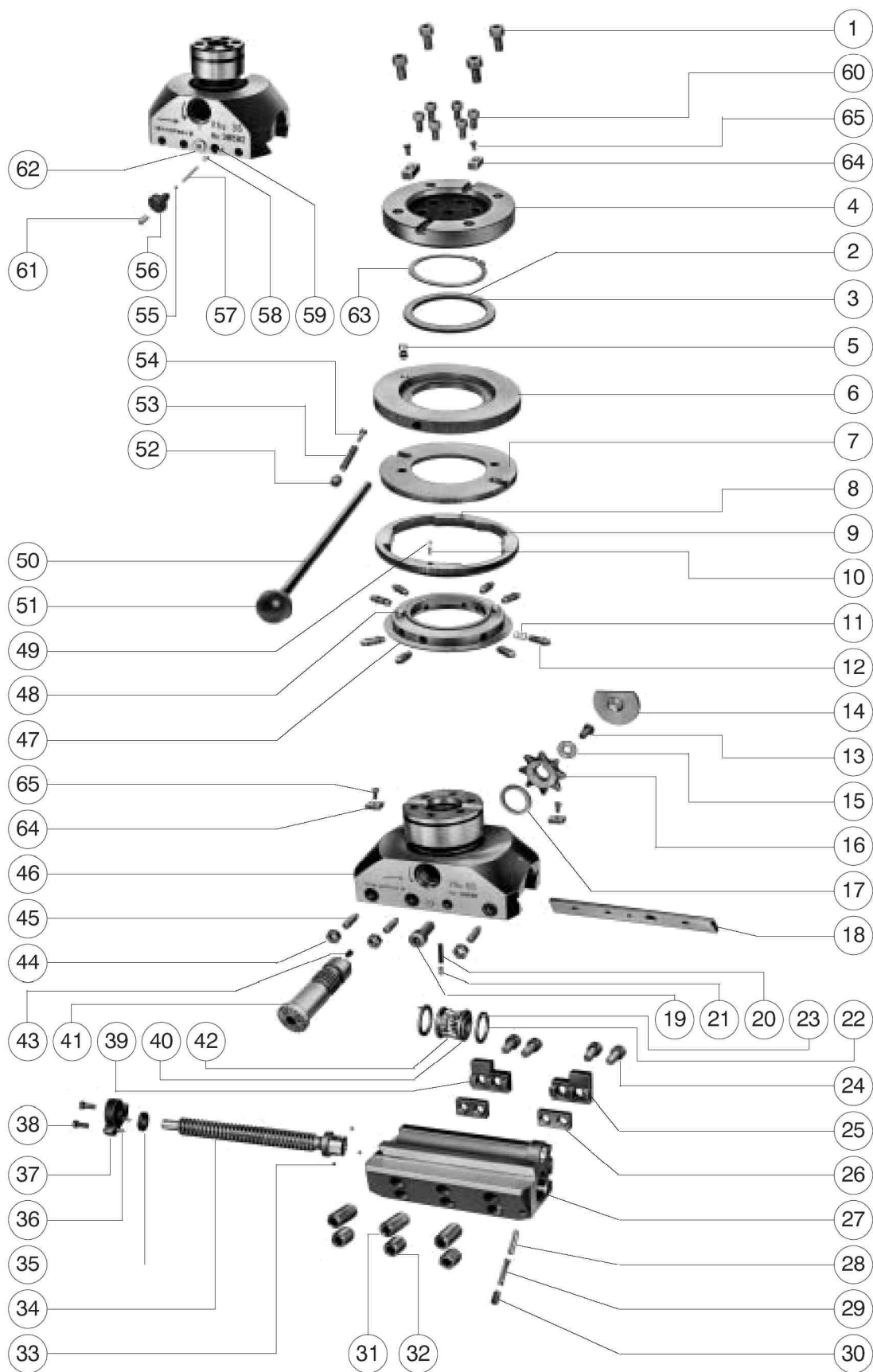

KUŽELOVÉ STOPKY VYMĚNITELNÉ AUSTAUSCHBARE KEGELSCHÄFTE ВЗАИМОЗАМЕНЯЕМЫЕ КОНИЧЕСКИЕ ХВОСТОВИКИ



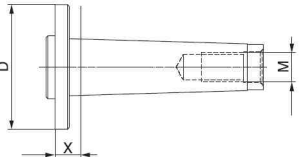
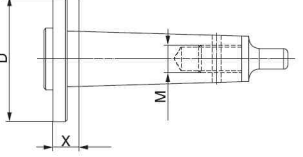
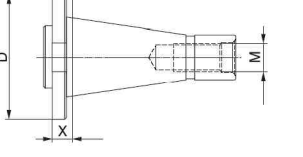
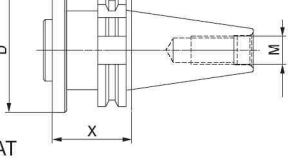



česky
deutsch
по-русски

VK	Kód Code Код	Popis Beschreibung Описание	Vhu 36	Vhu 56	Vhu 80	Vhu 110	Vhu 125	Vhu 160	Vh 70	Vh 110	Vh 140	Vhs 50/10-125	Vhs 40-180	D [mm]	X [mm]		Náčrt Zeichnung Эскиз
VK 360	208.015	MK2-M8 DIN 228A	●						●					70	13	0,35	
VK 360	208.022	MK2-M10 DIN 228A	●						●					70	13	0,35	
VK 360	208.039	MK2-3/8"-16 UNC	●						●					70	13	0,35	
VK 360	208.060	MK3-M10 DIN 228A	●						●					70	13	0,46	
VK 360	208.077	MK3-M12 DIN 228A	●						●					70	13	0,46	
VK 360	208.084	MK3-1/2"-12 UNC	●						●					70	13	0,46	
VK 360	208.121	MK4-M14 DIN 228A	●						●					70	14,5	0,75	
VK 360	208.138	MK4-M16 DIN 228A	●						●					70	14,5	0,75	
VK 360	208.145	MK4-5/8"-11 UNC	●						●					70	14,5	0,75	
VK 801	208.510	MK4-M14 DIN 228A		●	●	●				●	●	●	●	110	18,5	1,35	
VK 801	208.527	MK4-M16 DIN 228A		●	●	●				●	●	●	●	110	18,5	1,35	
VK 801	208.534	MK4-5/8"-11 UNC		●	●	●				●	●	●	●	110	18,5	1,35	
VK 801	208.572	MK5-M16 DIN 228A		●	●	●	●	●		●	●	●	●	110	18,5	2,29	
VK 801	208.589	MK5-M20 DIN 228A		●	●	●	●	●		●	●	●	●	110	18,5	2,29	
VK 801	208.596	MK5-3/4"-10 UNC		●	●	●	●	●		●	●	●	●	110	18,5	2,29	
VK 801	208.633	MK6-M20 DIN 228A		●	●	●	●	●		●	●	●	●	110	20	4,74	
VK 801	208.640	MK6-M24 DIN 228A		●	●	●	●	●		●	●	●	●	110	20	4,74	
VK 801	208.664	MK6-1"-8 UNC		●	●	●	●	●		●	●	●	●	110	20	4,74	
VK 360	208.053	MK3-DIN 1806	●						●					70	13	0,47	
VK 360	208.114	MK4-DIN 1806	●						●					70	14,5	0,77	
VK 360	208.169	MK5-DIN 1806	●						●					70	14,5	1,5	
VK 360	208.176	MK6-DIN 1806	●						●					70	38	4,16	
VK 801	208.503	MK4-DIN 1806		●	●	●				●	●	●	●	110	18,5	1,47	
VK 801	208.565	MK5-DIN 1806		●	●	●	●	●		●	●	●	●	110	18,5	2,45	
VK 801	208.626	MK6-DIN 1806		●	●	●	●	●		●	●	●	●	110	20	4,54	
VK 360	208.046	MK2-(3/8"-16 UNC) *	●						●					70	13	0,36	
VK 360	208.091	MK3-(M12) *	●						●					70	13	0,47	
VK 360	208.107	MK3-(1/2"-13 UNC) *	●						●					70	13	0,47	
VK 360	208.152	MK4-(5/8"-11 UNC) *	●						●					70	14,5	0,75	
VK 801	208.541	MK4-(M16) *		●	●	●				●	●	●	●	110	18,5	1,46	
VK 801	208.558	MK4-(5/8"-12 UNC) *		●	●	●				●	●	●	●	110	18,5	1,46	
VK 801	208.602	MK5-(M20) *		●	●	●	●	●		●	●	●	●	110	18,5	2,22	
VK 801	208.619	MK5-(3/4"-10 UNC) *		●	●	●	●	●		●	●	●	●	110	18,5	2,22	
VK 801	208.671	MK6-(M24) *		●	●	●	●	●		●	●	●	●	110	20	4,53	
VK 801	208.688	MK6-(1"-8 UNC) *		●	●	●	●	●		●	●	●	●	110	20	4,53	
VK 360	208.183	ISO 30 (M12) DIN 2080	●						●					70	9,6	0,4	
VK 360	208.190	ISO 30 (1/2"-13 UNC)	●						●					70	9,6	0,4	
VK 360	208.213	ISO 40 (M16) DIN 2080	●						●					70	9,6	0,74	
VK 360	208.220	ISO 40 (5/8"-11 UNC)	●						●					70	9,6	0,74	
VK 360	208.244	ISO 50 (M24) DIN 2080	●						●					70	45,2	3,19	
VK 801	208.695	ISO 40-(M16) DIN 2080		●	●	●	●	●		●	●	●	●	110	13,6	1,35	
VK 801	208.701	ISO 40-(5/8"-11 UNC)		●	●	●	●	●		●	●	●	●	110	13,6	1,35	
VK 801	208.725	ISO 50-(M24) DIN 2080		●	●	●	●	●		●	●	●	●	110	15,2	2,89	
VK 801	208.732	ISO 50-(1"-8 UNC)		●	●	●	●	●		●	●	●	●	110	15,2	2,89	
VK 360	208.206	ISO 30 (M12) DIN 69871/A	●						●					70	49,1	0,75	
VK 360	208.282	CAT 30 (1/2"-13 UNC)	●						●					70	44,2	0,75	
VK 360	208.237	ISO 40 (M16) DIN 69871/A	●						●					70	49,1	1,35	
VK 360	208.299	CAT 40 (5/8"-11 UNC)	●						●					70	49,1	1,35	
VK 360	208.251	ISO 50 (M24) DIN 69871/A	●						●					70	49,1	3,05	
VK 801	208.718	ISO 40-(M16) DIN 69871/A		●	●	●	●	●		●	●	●	●	110	48,1	1,95	
VK 801	208.770	CAT 40-(5/8"-11 UNC)		●	●	●	●	●		●	●	●	●	110	48,1	1,95	
VK 801	208.749	ISO 50-(M24) DIN 69871/A		●	●	●	●	●		●	●	●	●	110	65,1	4,78	
VK 801	208.787	CAT 50-(1"-8 UNC)		●	●	●	●	●		●	●	●	●	110	65,1	4,78	
VK 360	208.268	MAS-BT30 (M12)	●						●					70	34,6	0,70	
VK 360	208.275	MAS-BT40 (M16)	●						●					70	57,0	1,55	
VK 801	208.756	MAS-BT40 (M16)		●	●	●	●	●		●	●	●	●	110	43,6	2,12	
VK 801	208.763	MAS-BT50 (M24)		●	●	●	●	●		●	●	●	●	110	84,0	5,70	
VK 360	208.305	R8 (7/16"-20 UNF)	●						●					70	17,6	0,69	
VK 800	208.817	R8 (7/16"-20 UNF)	●						●					63	17,6	0,64	

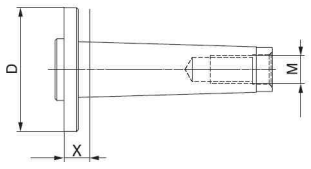
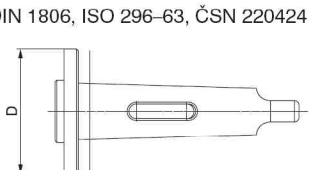
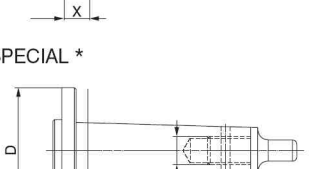
KUŽELOVÉ STOPKY VYMĚNITELNÉ

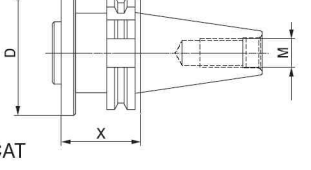
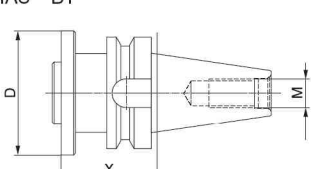
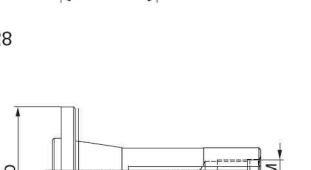
EXCHANGEABLE TAPER SHANKS REPLACEABLE

ESPIGAS CÓNICAS REEMPLAZABLES

VK	Kód Code Código	Popis Description Descripción	V/hu 36	V/hu 56	V/hu 80	V/hu 110	V/hu 125	V/hu 160	V/hu 70	V/h 110	V/h 140	V/hš 50/10/125	V/hš 40-180	D [mm]	X [mm]		Náčrt Drawing Croquis
VK 360	208.015	MK2-M8 DIN 228A	●						●			●		70	13	0,35	
VK 360	208.022	MK2-M10 DIN 228A	●						●			●		70	13	0,35	
VK 360	208.039	MK2-3/8"-16 UNC	●						●			●		70	13	0,35	
VK 360	208.060	MK3-M10 DIN 228A	●						●			●		70	13	0,46	
VK 360	208.077	MK3-M12 DIN 228A	●						●			●		70	13	0,46	
VK 360	208.084	MK3-1/2"-12 UNC	●						●			●		70	13	0,46	
VK 360	208.121	MK4-M14 DIN 228A	●						●			●		70	14,5	0,75	
VK 360	208.138	MK4-M16 DIN 228A	●						●			●		70	14,5	0,75	
VK 360	208.145	MK4-5/8"-11 UNC	●						●			●		70	14,5	0,75	
VK 801	208.510	MK4-M14 DIN 228A		●	●	●			●			●		110	18,5	1,35	
VK 801	208.527	MK4-M16 DIN 228A		●	●	●			●			●		110	18,5	1,35	
VK 801	208.534	MK4-5/8"-11 UNC		●	●	●			●			●		110	18,5	1,35	
VK 801	208.572	MK5-M16 DIN 228A		●	●	●	●		●	●		●		110	18,5	2,29	
VK 801	208.589	MK5-M20 DIN 228A		●	●	●	●		●	●		●		110	18,5	2,29	
VK 801	208.596	MK5-3/4"-10 UNC		●	●	●	●		●	●		●		110	18,5	2,29	
VK 801	208.633	MK6-M20 DIN 228A		●	●	●	●		●	●		●		110	20	4,74	
VK 801	208.640	MK6-M24 DIN 228A		●	●	●	●		●	●		●		110	20	4,74	
VK 801	208.664	MK6-1"-8 UNC		●	●	●	●		●	●		●		110	20	4,74	
VK 360	208.053	MK3-DIN 1806	●						●			●		70	13	0,47	
VK 360	208.114	MK4-DIN 1806	●						●			●		70	14,5	0,77	
VK 360	208.169	MK5-DIN 1806	●						●			●		70	14,5	1,5	
VK 360	208.176	MK6-DIN 1806	●						●			●		70	38	4,16	
VK 801	208.503	MK4-DIN 1806		●	●	●			●	●		●		110	18,5	1,47	
VK 801	208.565	MK5-DIN 1806		●	●	●	●		●	●		●		110	18,5	2,45	
VK 801	208.626	MK6-DIN 1806		●	●	●	●		●	●		●		110	20	4,54	
VK 360	208.046	MK2-(3/8"-16 UNC) *	●						●			●		70	13	0,36	
VK 360	208.091	MK3-(M12) *	●						●			●		70	13	0,47	
VK 360	208.107	MK3-(1/2"-13 UNC) *	●						●			●		70	13	0,47	
VK 360	208.152	MK4-(5/8"-11 UNC) *	●						●			●		70	14,5	0,75	
VK 801	208.541	MK4-(M16) *		●	●	●			●	●		●		110	18,5	1,46	
VK 801	208.558	MK4-(5/8"-12 UNC) *		●	●	●			●	●		●		110	18,5	1,46	
VK 801	208.602	MK5-(M20) *		●	●	●	●		●	●		●		110	18,5	2,22	
VK 801	208.619	MK5-(3/4"-10 UNC) *		●	●	●	●		●	●		●		110	18,5	2,22	
VK 801	208.671	MK6-(M24) *		●	●	●	●		●	●		●		110	20	4,53	
VK 801	208.688	MK6-(1"-8 UNC) *		●	●	●	●		●	●		●		110	20	4,53	
VK 360	208.183	ISO 30 (M12) DIN 2080	●						●			●		70	9,6	0,4	
VK 360	208.190	ISO 30 (1/2"-13 UNC)	●						●			●		70	9,6	0,4	
VK 360	208.213	ISO 40 (M16) DIN 2080	●						●			●		70	9,6	0,74	
VK 360	208.220	ISO 40 (5/8"-11 UNC)	●						●			●		70	9,6	0,74	
VK 360	208.244	ISO 50 (M24) DIN 2080	●						●			●		70	45,2	3,19	
VK 801	208.695	ISO 40-(M16) DIN 2080		●	●	●	●		●	●		●		110	13,6	1,35	
VK 801	208.701	ISO 40-(5/8"-11 UNC)		●	●	●	●		●	●		●		110	13,6	1,35	
VK 801	208.725	ISO 50-(M24) DIN 2080		●	●	●	●		●	●		●		110	15,2	2,89	
VK 801	208.732	ISO 50-(1"-8 UNC)		●	●	●	●		●	●		●		110	15,2	2,89	
VK 360	208.206	ISO 30 (M12) DIN 69871/A	●						●			●		70	49,1	0,75	
VK 360	208.282	CAT 30 (1/2"-13 UNC)	●						●			●		70	44,2	0,75	
VK 360	208.237	ISO 40 (M16) DIN 69871/A	●						●			●		70	49,1	1,35	
VK 360	208.299	CAT 40 (5/8"-11 UNC)	●						●			●		70	49,1	1,35	
VK 360	208.251	ISO 50 (M24) DIN 69871/A	●						●			●		70	49,1	3,05	
VK 801	208.718	ISO 40-(M16) DIN 69871/A		●	●	●	●		●	●		●		110	48,1	1,95	
VK 801	208.770	CAT 40-(5/8"-11 UNC)		●	●	●	●		●	●		●		110	48,1	1,95	
VK 801	208.749	ISO 50-(M24) DIN 69871/A		●	●	●	●		●	●		●		110	65,1	4,78	
VK 801	208.787	CAT 50-(1"-8 UNC)		●	●	●	●		●	●		●		110	65,1	4,78	
VK 360	208.268	MAS-BT30 (M12)	●						●			●		70	34,6	0,70	
VK 360	208.275	MAS-BT40 (M16)	●						●			●		70	57,0	1,55	
VK 801	208.756	MAS-BT40 (M16)		●	●	●	●		●	●		●		110	43,6	2,12	
VK 801	208.763	MAS-BT50 (M24)		●	●	●	●		●	●		●		110	84,0	5,70	
VK 360	208.305	R8 (7/16"-20 UNF)	●						●			●		70	17,6	0,69	
VK 800	208.817	R8 (7/16"-20 UNF)		●										63	17,6	0,64	

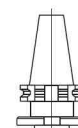

česky
english
español