

# FRÉZOVANIE HRÁN

na otvoroch, viachranoch a trubkách

by System KOPAL

## SORTIMENT VYMENITEĽNÝCH NOŽOV

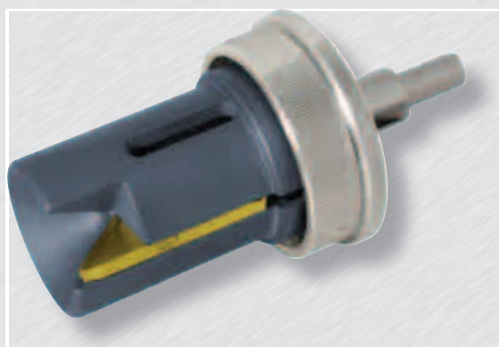

### Frézy na hrany

- Princíp
- Vnútoré hrany
- Vnútoré hrany - Slim line
- Vonkajšie hrany
- Frézy na trubky - KOPAL Tube
- Náhradné diely
- Vymeniteľné nože

## Vnútorne hrany

Upínací uhol 0° pre model:	60°	90°	82°	120°	60°	90°
2 - 18	HSS				Tvrdokov	
2 - 42	01-303	01-323		01-334		
20 - 60 bis 80 - 120	01-343	01-353	01-336	01-364	01-341	01-351

Upínací uhol 14° pre model :	60°	90°	82°	120°
2 - 18	HSS			
2 - 42	01-305	01-320		01-335
20 - 60 bis 80 - 120	01-340	01-350	01-345	01-360
	01-365	01-370		

Upínací uhol 20° pre model:	60°	90°	82°	120°	60°	90°
2 - 18	HSS				TIN	
2 - 42	01-308	01-328		01-338	1T305B	1T320B
20 - 60 bis 80 - 120	01-348	01-358	01-342	01-368	1T340B	1T350B
	01-361	01-378				

Upínací uhol 25° pre model :	60°	90°	82°	120°
2 - 18	HSS			
2 - 42	01-309	01-329		01-339
20 - 60 bis 80 - 120	01-349	01-359	01-344	01-369
	01-362	01-379		

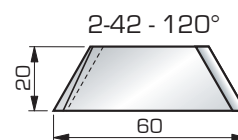
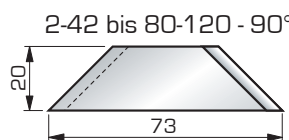
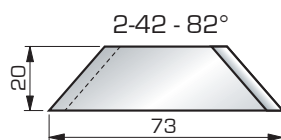
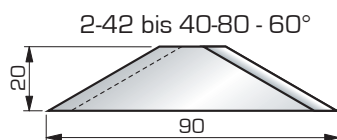
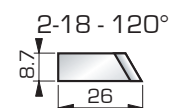
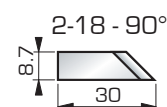
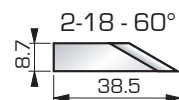

- HSS- Nože - 0° do 25°  
Štandard Materiály
- HSS- Nože- TIN - 20°  
Ťažšie obrábanie : nerez  
ocele, Inconel, Titan
- TK nože - 0°  
hlavne pre tvrdé materiály

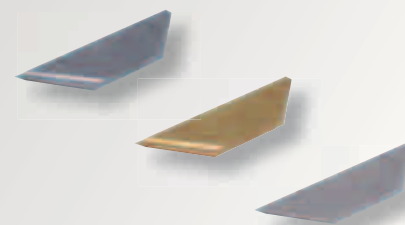

## Vonkajšie hrany

Upínací uhol 0° pre model:	60°	90°
2 - 18	HSS	
2 - 36 bis 80 - 120	02-303	02-304
	02-317	02-312

Upínací uhol 14° pre model:	60°	90°
2 - 18	HSS	
2 - 36 bis 80 - 120	02-305	02-300
	02-315	02-310

Upínací uhol 20° pre model:	60°	90°	60°	90°
2 - 18	HSS		TIN	
2 - 36 bis 80 - 120	02-308	02-302	2T305B	2T300B
	02-318	02-313	2T315B	2T310B

Upínací uhol 25° pre model:	60°	90°
2 - 18	HSS	
2 - 36 bis 80 - 120	02-307	02-306
	02-319	02-314

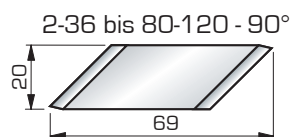
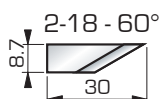
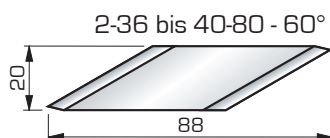
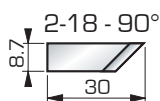

## Vnútorne hrany Slim Line

Upínací uhol 0° pre model :	60°	90°	90° Tvrdokov
	HSS		
	03-312	03-322	
	03-302	03-321	
4-42		03-352	01-351
Upínací uhol 14° pre model :	60°	90°	
	HSS		
	03-310	03-320	
	03-305	03-300	
4-42		03-350	
Upínací uhol 20° pre model :	60°	90°	
	HSS		
	03-313	03-323	
	03-308	03-328	
4-42		03-358	
Upínací uhol 25° pre model :	60°	90°	
	HSS		
	03-314	03-324	
	03-309	03-329	
4-42		03-359	

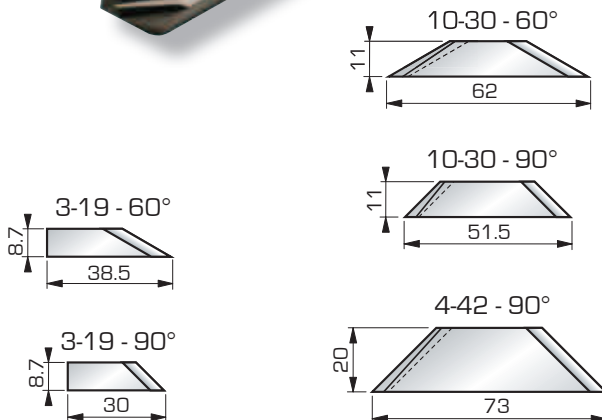

**Funkčne môžete nástroj porovnať z tesárskym hoblíkom.**

Nôž vám poskytne hrúbku triesky na jednu reznú hranu

pr. : s hrúbkou triesky 0,1mm je potrebných 10 otáčok pre vytvorenie hrany 1 mm

**Odporúčané rezné parametre:**

**medzi 10 und 20 m/min.**

pr. : Ø 10 mm	320 - 640 rpm
Ø 15 mm	210 - 420 rpm
Ø 20 mm	160 - 320 rpm
Ø 30 mm	110 - 220 rpm
Ø 40 mm	80 - 160 rpm
Ø 60 mm	55 - 110 rpm

$$U/min = \frac{\text{rezná rýchlosť} \times 1000}{\text{priemer} \times 3.14}$$

Namažte rezacím olejom alebo emulzným olejom, aby ste zaistili čo najdlhšiu životnosť noža a najmenšie opotrebenie vodiaceho kužela.

Material	Mosadz	Oceľ	Oceľ	Hliník
	Bronz	Bronz špeciál	meď	Mäkká liat
	Liatina	Plexisklo	AU 4 G	Plech
	Nerez oceľ		Plast	
	žiaruvzdorná oceľ		nerez oceľ	
Uhol nastavenia	0° HSS Tvrdokov	14° HSS	20° HSS	25° HSS

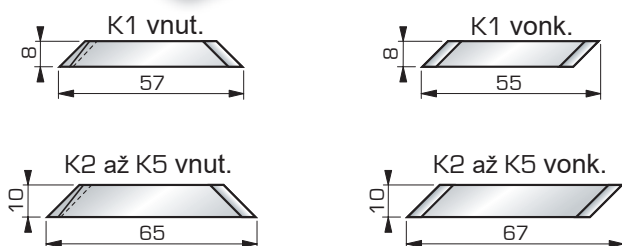

## Nože pre KOPAL TUBE

Upínací uhol 14° pre model:	vnut.	vonk.
	HSS	
	K 1	04-300 04-310
K 2 až K 5	04-320	04-330
Upínací uhol 20° pre model:	vnut.	vonk.
	HSS	
	K 1	04-303 04-313
K 2 až K 5	04-323	04-333