

# FRÉZOVANIE HRÁN

na otvoroch, viachranoch a trubkách

by System KOPAL

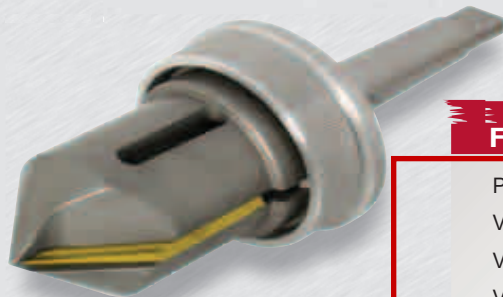
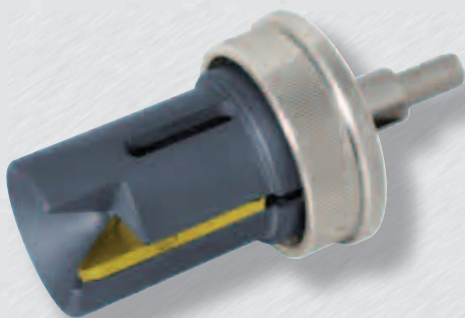

## Frézy na hrany

- Princíp
- Vnútorne hrany
- Vnútorne hrany - Slim line
- Vonkajšie hrany
- Frézy na trubky - KOPAL Tube
- Náhradné diely
- Vymeniteľné nože

Frézuje skosenie na všetkých okrajoch otvorov, či už je to valcový, viachranný alebo prerušovaný rez.

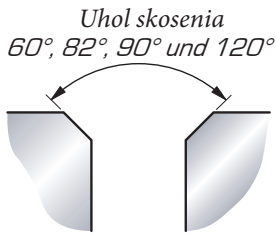
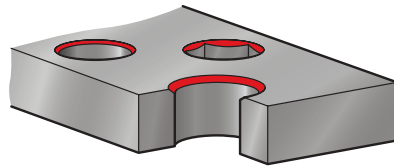

na valcových a viachranných otvoroch

stopka Ø



stopka CM Morse



## Frézy na vnútorné hrany

bez nožov

s vodiacim kuželom

priemer hrany	Model	Stopka	A	B	C 60°/90°	Štandard		CRN - Chromnitrid		Štandard	
						60° Best. Nr.	90° Best. Nr.	60° Best. Nr.	90° Best. Nr.	82° Best. Nr.	120° Best. Nr.
4 bis 17	2 - 18	Ø 10 CM 1	Ø 18	Ø 26	64/55	01-030	01-010	1W030B	1W010B	01-050	01-080
5 bis 41	2 - 42	Ø 10/16	Ø 42	Ø 65	108/85	01-120	01-095	1W120B	1W095B	01-150	01-191
		Ø 12.7				01-125	01-100	1W125B	1W100B		
		CM 1				01-115	01-090	1W115B	1W090B		
		CM 2				01-116	01-091	1W116B	1W091B		
		CM 3				01-117	01-092	1W117B	1W092B		
	weldon Ø19	01-093									
21 bis 59	20 - 60	CM 2	Ø 60	Ø 70	106/94	01-215	01-210				
42 bis 77	40 - 80	CM 2	Ø 80	Ø 90	114/100	01-230	01-225				
		CM 3				01-231	01-226				
62 bis 97	60 - 100	CM 3	Ø 100	Ø 110	104		01-241				
82 bis 117	80 - 120	CM 3	Ø 120	Ø 130	104		01-256				

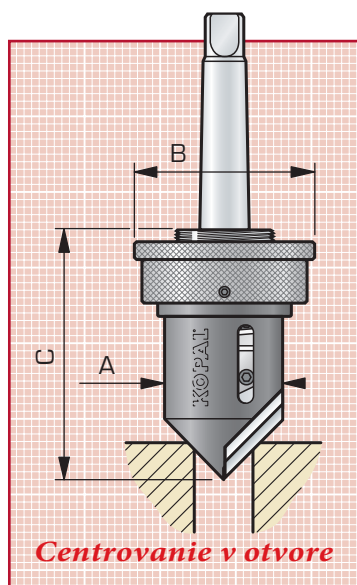

HSS-Nôž  
Rezný uhol 0° - 14° - 20° und 25°

HSS - Nôž - TiN  
Rezný uhol 20°

Tvrdokovový nôž  
Rezný uhol 0°

