

# FRÉZOVANIE HRÁN

na otvoroch, viachranoch a trubkách

by System KOPAL

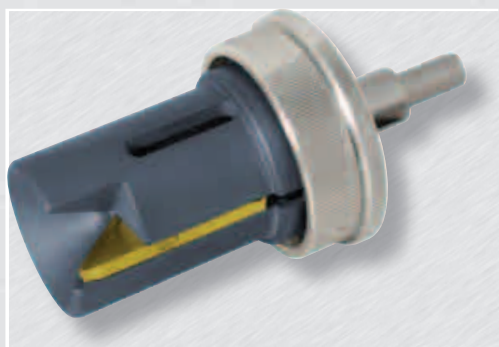

## Frézy na hrany!

- Princíp
- Vnútoré hrany
- Vnútoré hrany - Slim line
- Vonkajšie hrany
- Frézy na trubky - KOPAL Tube
- Náhradné diely
- Vymeniteľné nože

na valcových a viachranných materiáloch

Frézovanie všetkých rúr-

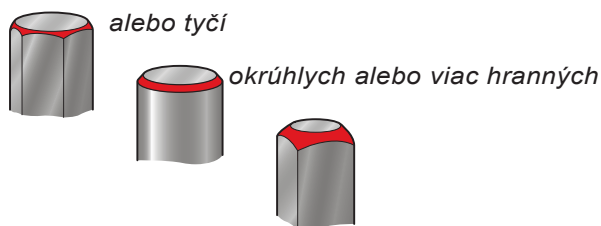

Uhol skosenia

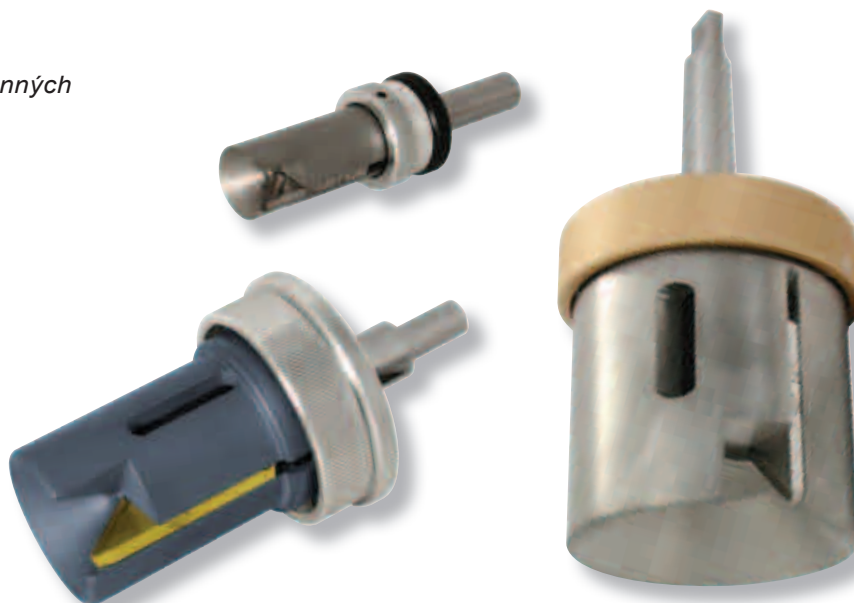

## Frézy na vonkajšie hrany

bez nožov



s vodiacim kuželom

Priemer hrany	Model	Stopka	A	B	C 60°/90°	Štandard		CRN - Chromnitrid	
						60° Best. Nr.	90° Best. Nr.	60° Best. Nr.	90° Best. Nr.
4 bis 17	<b>2 - 18</b>	∅ 10 CM 1	∅ 18	∅ 26	54	02-020	02-010	2W020B	2W010B
4 bis 37	<b>2 - 36</b>	∅ 10/16 CM 2	∅ 42	∅ 65	105/85	02-055	02-035	2W055B	2W035B
10 bis 45	<b>10 - 46</b>	∅ 10/16 CM 2	∅ 48	∅ 65	109/85	02-110	02-095		
21 bis 57	<b>20 - 60</b>	CM 2	∅ 60	∅ 70	108/85	02-105	02-090		
41 bis 77	<b>40 - 80</b>	CM 2 CM 3	∅ 80	∅ 90	118/95	02-140	02-135		
60 bis 97	<b>60 - 100</b>	CM 3	∅ 100	∅ 110	107	02-155	02-150		
80 bis 117	<b>80 - 120</b>	CM 3	∅ 120	∅ 130	110	02-156	02-151		
							02-166		
							02-181		

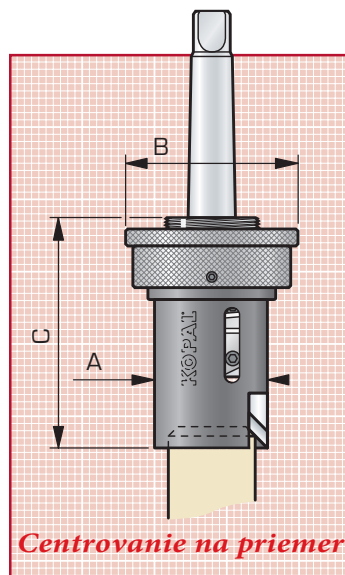

HSS-nože

Rezný uhol 0° - 14° - 20° und 25°

HSS-nože - TiN

Rezný uhol 20°

