

Hnané upínače CNC strojov.



Angetriebene

Werkzeuge

Driven Tools

Outils entraînés

Tahrikli Takım Tutucular

INHALTSVERZEICHNIS / INDEX	Seite / Page
Barruffaldi TOEM Axial / Radial Spannzangenaufnahme / Collet chuck Tetê de perçage axiale/radiale - Tahrikli pens başlığı Axial/Radial	6.01
Diplomatic DIN 1809 Axial / Radial Spannzangenaufnahme / Collet chuck Tetê de perçage axiale/radiale - Tahrikli pens başlığı Axial/Radial	6.04
Sauter-Revolver 5480 Axial / Radial Spannzangenaufnahme / Collet chuck Tetê de perçage axiale/radiale - Tahrikli pens başlığı Axial/Radial	6.07
Sauter-Revolver 5482 Axial / Radial Spannzangenaufnahme / Collet chuck Tetê de perçage axiale/radiale - Tahrikli pens başlığı Axial/Radial	6.10
Mori Seiki NL-NT Axial / Radial Spannzangenaufnahme / Collet chuck Tetê de perçage axiale/radiale - Tahrikli pens başlığı Axial/Radial	6.13
Mazak Nexus Axial / Radial Spannzangenaufnahme / Collet chuck Tetê de perçage axiale/radiale - Tahrikli pens başlığı Axial/Radial	6.15
Okuma Series Axial / Radial Spannzangenaufnahme / Collet chuck Tetê de perçage axiale/radiale - Tahrikli pens başlığı Axial/Radial	6.23
Doosan BMT / Radial Spannzangenaufnahme / Collet chuck Tetê de perçage radiale - Tahrikli pens başlığı Radial	6.24
Goodway Axial / Radial Spannzangenaufnahme / Collet chuck Tetê de perçage axiale/radiale - Tahrikli pens başlığı Axial/Radial	6.25
Takisawa Axial / Radial Spannzangenaufnahme / Collet chuck Tetê de perçage axiale/radiale - Tahrikli pens başlığı Axial/Radial	6.26



PANAS Tools s.r.o.
Hradište č, 371, SK - 958 54
Tel. : +421/38/749 67 64 - 65
WWW.panas.sk
info@panas.sk

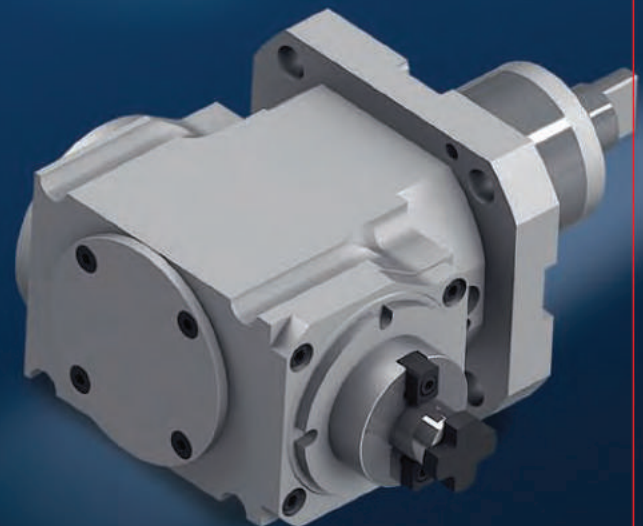
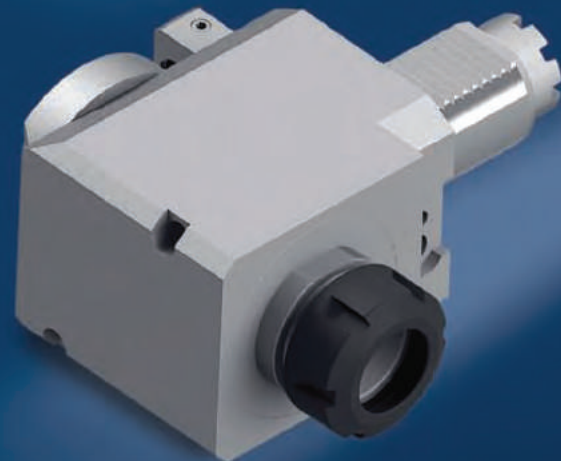
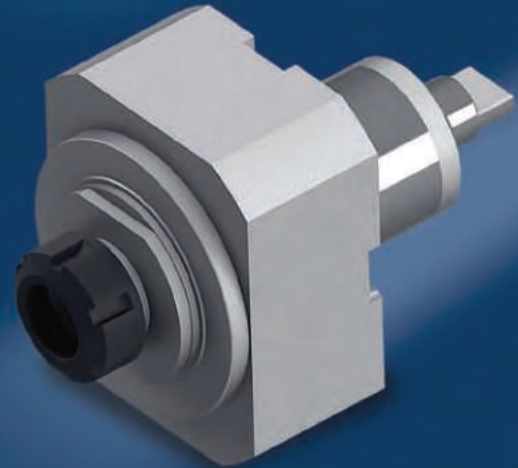



Angetriebene Werkzeuge

Driven Tools

Outils entraînés

Tahrikli Takım Tutucular

Technische Daten

- Dauerhafte Bearbeitungsperformance und Schneidleistung
- Nullpunktjustierung somit kurze Einstellzeit
- Optimale Dichtigkeit mit speziellem Walzenöl. Wartungsarm, längere Lebensdauer der eingesetzten Werkzeuge
- maximale Kraftübertragung durch ausgewählte Zahnräder
- Externes Kühlungssystem
- Rundlaufgenauigkeit $\leq 0,01$
- Schaft gemäß DIN 69880
- Achsenparallelität $\leq 0,02$
- EROGLU Qualitätsgarantie.

Technical Data

- Durable processing performance and cutting power
- Zero-point-adjustment and therefore short adjustment time
- Optimal density with special oil, longer life time of the used tools
- Maximum power transmission by selected gears
- External cooling system
- Concentricity accuracy $\leq 0,01$
- Shank according to DIN 69880
- Axis parallelism $\leq 0,02$
- EROGLU quality guarantee

Données Techniques:

- Performance d'usinage stable
- Mise à zero rapide, gain de temps de réglage
- Etanchéité optimale. Durée de vie élevée traitement de surface spécifique.
- Transmission du couple par selections de pignons
- Arrosage externe
- Concentricité $\leq 0,01$
- queue selon DIN 69880
- parallélisme des axes $\leq 0,02$
- EROGLU garantie de qualité

Teknik Bilgi

- Güçlü spindle rulmanları sayesinde yüksek rijitlik ve mükemmel kesme performansı
- Geniş sıfırlama yüzeyi ve ayarlama civataları sayesinde doğru ve hızlı ayarlama imkanı
- Özel yağlar ve sızdırmazlık elemanları sayesinde uzun ömür ve uzun bakım periyotları
- Yüksek devirde çalışmaya müsait, taşlanmış dişli sayesinde sessiz, hassas çalışma ve yüksek tork iletimi
- Kesiciyi en iyi soğutacak şekilde ayarlanabilir dıştan soğutma sistemi
- Düşük salgı değerleri $\leq 0,01$
- DIN 69880 normuna ve tezgah özelliklerine tam uyum
- Hassas eksen paralellikleri $\leq 0,02$
- EROGLU kalitesi ve güvencesiyle



Typ A



Typ B



Baruffaldi TOEM



DIN 1809



DIN 5480



DIN 5482



MORI SEIKI - NL- NT SERIES



OKUMA SERIES



Axial drilling - milling head collet chuck DIN 6499

Tetê de percage - fraisage axiale mandrin pour pinces DIN 6499

Axial Tahrikli Takım Tutucu Pens Başlığı DIN 6499

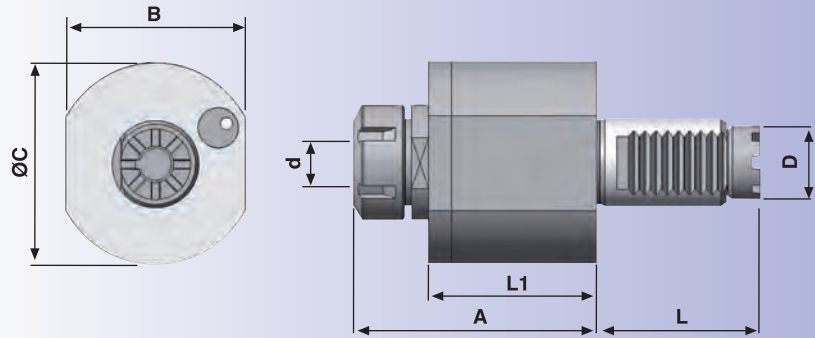

Bestell-Nr. Order Nr. Référence Sipariş Nr.	D	Spannzangen Collet Pincas Pens	d	A	L	L1	B	Ø C	N.Max. (1/min)	i i / i	T.max. (Nm)	Euro
311.0216.11	30	ER 25	2-16	89	59	58	62	70	6.000	1/1	25	
411.0220.11	40	ER 32	2-20	112,5	68	76	76	94	6.000	1/1	50	
411.0226.11	40	ER 40	3-26	126,5	68	76	76	94	6.000	1/1	50	
511.0220.11	50	ER 32	2-20	117,5	84	80	88	102	5.000	1/1	80	
511.0226.11	50	ER 40	3-26	122	84	80	88	102	5.000	1/1	80	

Axial Fräskopf Fräsdornaufnahme DIN 6357

Axial milling head chuck for cutter arbor DIN 6357

Tetê de fraisage axiale porte - fraise DIN 6357

Axial Tahrikli Takım Tutucu Alın Kamalı Malafa DIN 6357

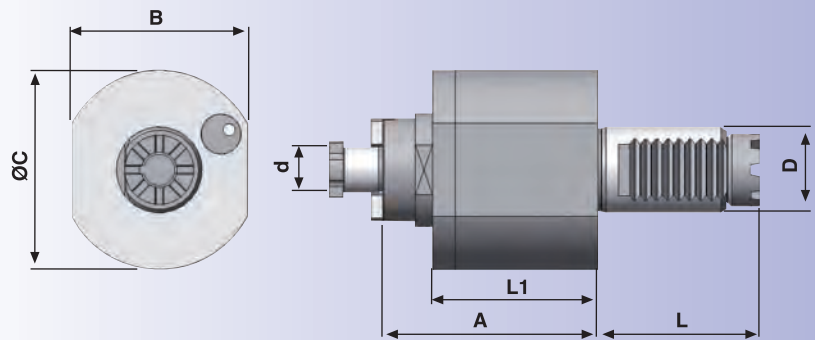

Bestell-Nr. Order Nr. Référence Sipariş Nr.	D	d	A	L	L1	B	Ø C	N.Max. (1/min)	i i / i	T.max. (Nm)	Euro
311.1116.11	30	16	71	59	58	62	70	6.000	1/1	25	
411.1116.11	40	16	104,5	68	76	76	94	6.000	1/1	50	
411.1122.11	40	22	104,5	68	76	76	94	6.000	1/1	50	
511.1122.11	50	22	95	84	80	88	102	5.000	1/1	80	
511.1127.11	50	27	96	84	80	88	102	5.000	1/1	80	

**Radial Bohr - und Fräskopf Spannzangenaufnahme DIN 6499**

Baruffaldi TOEM

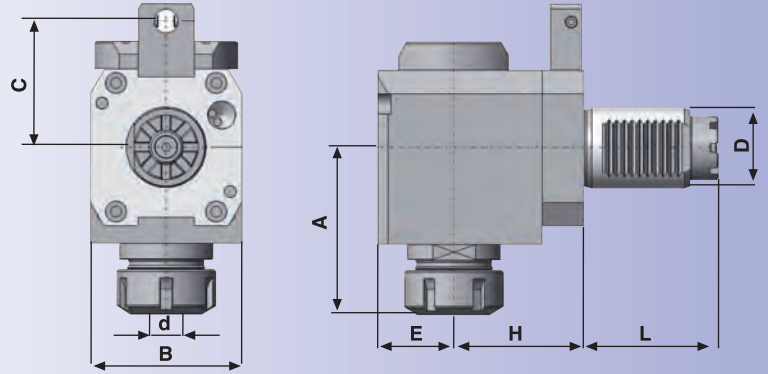
Radial drilling - milling head collet chuck DIN 6499**Tête de perçage - fraisage radiale mandrin pour pinces DIN 6499****Radial Tahrikli Takım Tutucu Pens Başlığı DIN 6499**

Bestell-Nr. Order Nr. Référence Sipariş Nr.	D	Spannzangen Collet Pinces Pens	d	A	E	H	L	B	C	N.Max. (1/min)	i i / i	T.max. (Nm)	Euro
312.0216.11.A	30	ER 25	2-16	67	26	55	59	64	40	6.000	1/1	25	
312.0216.11.B	30	ER 25	2-16	67	26	55	59	64	40	6.000	1/1	25	
412.0220.11.A	40	ER 32	2-20	85	38	65	68	76	63	6.000	1/1	50	
412.0220.11.B	40	ER 32	2-20	85	38	65	68	76	63	6.000	1/1	50	
412.0226.11.A	40	ER 40	3-26	98	38	65	68	76	63	6.000	1/1	50	
412.0226.11.B	40	ER 40	3-26	98	38	65	68	76	63	6.000	1/1	50	
512.0220.11.A	50	ER 32	2-20	92.5	44	75	84	88	70	5.000	1/1	80	
512.0220.11.B	50	ER 32	2-20	92.5	44	75	84	88	70	5.000	1/1	80	
512.0226.11.A	50	ER 40	3-26	98	44	75	84	88	70	5.000	1/1	80	
512.0226.11.B	50	ER 40	3-26	98	44	75	84	88	70	5.000	1/1	80	

Radial Bohr - und Fräskopf Spannzangenaufnahme - versetzt DIN 6499

Baruffaldi TOEM

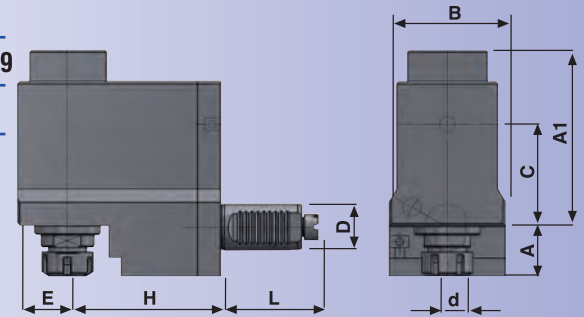
Radial drilling - milling head collet chuck - shifted DIN 6499**Tête de perçage - fraisage radiale mandrin pour pinces - décalé DIN 6499****Radial Tahrikli Takım Tutucu Pens Başlığı - eksenden kaçık DIN 6499**

Bestell-Nr. Order Nr. Référence Sipariş Nr.	D	Spannzangen Collet Pinces Pens	d	A	A1	E	H	L	B	C	N.Max. (1/min)	i i / i	T.max. (Nm)	Euro
314.0216.11.A	30	ER 25	2-16	35	102,3	32,5	85	59	64	40	6.000	1/1	40	
314.0216.11.B	30	ER 25	2-16	35	102,3	32,5	85	59	64	40	6.000	1/1	40	
414.0220.11.A	40	ER 32	2-20	40	115,5	38	100	68	76	63	5.000	1/1	70	
414.0220.11.B	40	ER 32	2-20	40	115,5	38	100	68	76	63	5.000	1/1	70	
514.0226.11.A	50	ER 40	3-26	45	133,5	45	110	84	88	70	4.000	1/1	100	
514.0226.11.B	50	ER 40	3-26	45	133,5	45	110	84	88	70	4.000	1/1	100	



Radial milling head chuck for cutter arbor DIN 6357

Tête de fraisage radiale porte - fraise DIN 6357

Radial Tahrikli Takım Tutucu Alın Kamalı Malafa DIN 6357

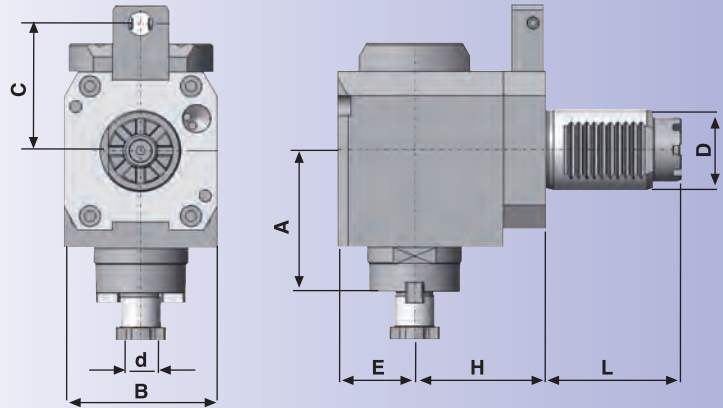

Bestell-Nr. Order Nr. Référence Sipariş Nr.	D	d	A	E	H	L	B	C	N.Max. (1/min)	i i / i	T.max. (Nm)	Euro
312.1116.11.A	30	16	49	26	55	59	64	40	6.000	1/1	25	
312.1116.11.B	30	16	49	26	55	59	64	40	6.000	1/1	25	
412.1116.11.A	40	16	64	38	65	68	76	63	6.000	1/1	50	
412.1116.11.B	40	16	64	38	65	68	76	63	6.000	1/1	50	
412.1122.11.A	40	22	64	38	65	68	76	63	6.000	1/1	50	
412.1122.11.B	40	22	64	38	65	68	76	63	6.000	1/1	50	
512.1122.11.A	50	22	71	44	75	84	88	70	5.000	1/1	80	
512.1122.11.B	50	22	71	44	75	84	88	70	5.000	1/1	80	
512.1127.11.A	50	27	71	44	75	84	88	70	5.000	1/1	80	
512.1127.11.B	50	27	71	44	75	84	88	70	5.000	1/1	80	

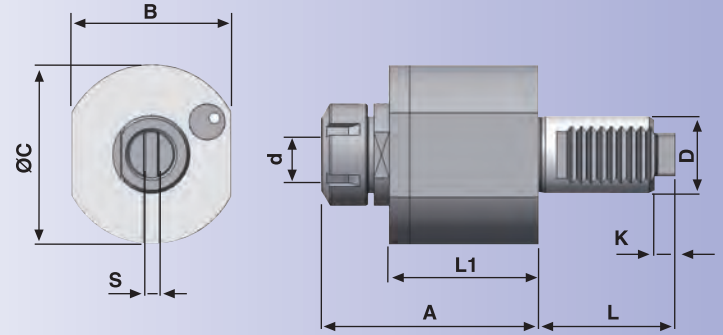
**Axial Bohr - und Fräskopf Spannzangenaufnahme DIN 6499****Diplomatic DIN 1809****Axial drilling - milling head collet chuck DIN 6499****Tête de perçage - fraisage axiale mandrin pour pinces DIN 6499****Axial Tahrikli Takım Tutucu Pens Başlığı DIN 6499**

Bestell-Nr. Order Nr. Référence Sipariş Nr.	D	Spannzangen Collet Pincas Pens	d	A	L	L1	B	ØC	K	S	N.Max. (1/min)	i i/i	T.max. (Nm)	Euro
321.0216.11	30	ER 25	2-16	89	62	58	62	70	7	6	6.000	1/1	25	
421.0220.11	40	ER 32	2-20	112.5	72	76	76	94	9	8	6.000	1/1	50	
421.0226.11	40	ER 40	3-26	126.5	72	76	76	94	9	8	6.000	1/1	50	
521.0220.11	50	ER 32	2-20	117.5	92	80	88	102	13	13	5.000	1/1	80	
521.0226.11	50	ER 40	3-26	122	92	80	88	102	13	13	5.000	1/1	80	

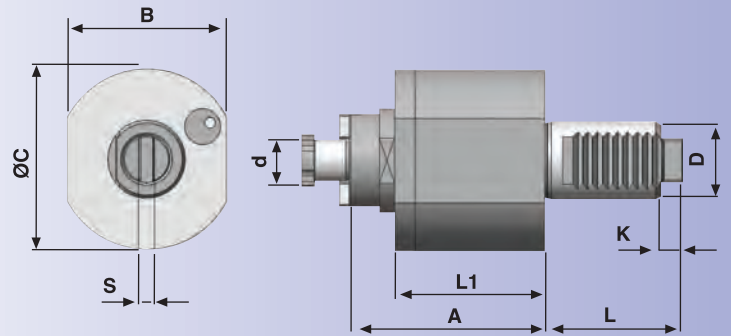
Axial Fräskopf Fräsdornaufnahme DIN 6357**Diplomatic DIN 1809****Axial milling head chuck for cutter arbor DIN 6357****Tête de fraisage axiale porte - fraisage DIN 6357****Axial Tahrikli Takım Tutucu Alın Kamalı Malafa DIN 6357**

Bestell-Nr. Order Nr. Référence Sipariş Nr.	D	d	A	L	L1	B	ØC	K	S	N.Max. (1/min)	i i/i	T.max. (Nm)	Euro
321.1116.11	30	16	71	62	58	62	70	7	6	6.000	1/1	25	
421.1116.11	40	16	104.5	72	76	76	94	9	8	6.000	1/1	50	
421.1122.11	40	22	104.5	72	76	76	94	9	8	6.000	1/1	50	
521.1122.11	50	22	95	92	80	88	102	13	13	5.000	1/1	80	
521.1127.11	50	27	96	92	80	88	102	13	13	5.000	1/1	80	



Radial drilling - milling head collet chuck DIN 6499

Tetê de perçage - fraisage radiale mandrin pour pinces DIN 6499

Radial Tahrikli Takım Tutucu Pens Başlığı DIN 6499

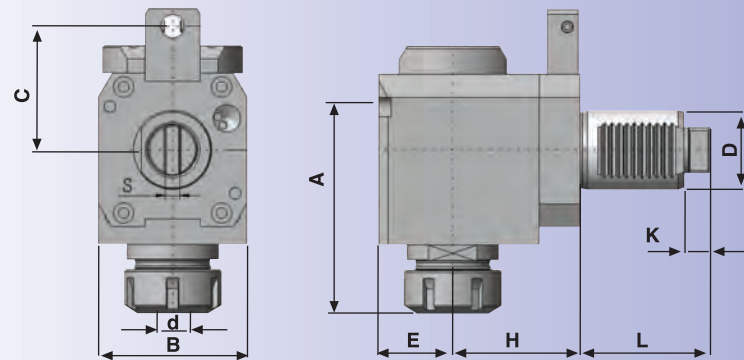

Bestell-Nr. Order Nr. Référence Sipariş Nr.	D	Spannzangen Collet Pinces Pens	d	A	E	H	L	B	K	S	C	N.Max. (1/min)	i i/i	T.max. (Nm)	Euro
322.0216.11.A	30	ER 25	2-16	67	26	55	62	64	7	6	40	6.000	1/1	25	
322.0216.11.B	30	ER 25	2-16	67	26	55	62	64	7	6	40	6.000	1/1	25	
422.0220.11.A	40	ER 32	2-20	85	38	65	72	76	9	8	63	6.000	1/1	50	
422.0220.11.B	40	ER 32	2-20	85	38	65	72	76	9	8	63	6.000	1/1	50	
422.0226.11.A	40	ER 40	3-26	98	38	65	72	76	9	8	63	6.000	1/1	50	
422.0226.11.B	40	ER 40	3-26	98	38	65	72	76	9	8	63	6.000	1/1	50	
520.0220.11.A	50	ER 32	2-20	92,5	44	75	92	88	13	13	70	5.000	1/1	80	
520.0220.11.B	50	ER 32	2-20	92,5	44	75	92	88	13	13	70	5.000	1/1	80	
522.0226.11.A	50	ER 40	3-26	98	44	75	92	88	13	13	70	5.000	1/1	80	
522.0226.11.B	50	ER 40	3-26	98	44	75	92	88	13	13	70	5.000	1/1	80	

Radial Bohr - und Fräskopf Spannzangenaufnahme - versetzt DIN 6499

Diplomatic DIN 1809

Radial drilling - milling head collet chuck - shifted DIN 6499

Tetê de perçage - fraisage radiale mandrin pour pinces - décalé DIN 6499

Radial Tahrikli Takım Tutucu Pens Başlığı DIN 6499 - eksenden kaçık

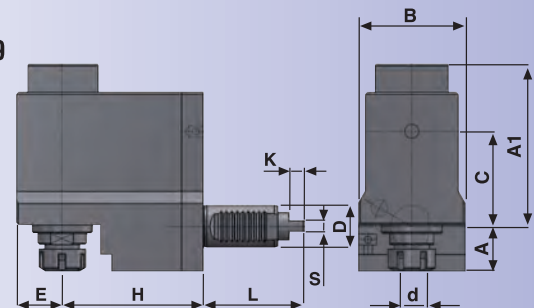

Bestell-Nr. Order Nr. Référence Sipariş Nr.	D	Spannzangen Collet Pinces Pens	d	A	A1	E	H	L	B	C	K	S	N.Max. (1/min)	i i/i	T.max. (Nm)	Euro
324.0216.11.A	30	ER 25	2-16	35	102,3	32,5	85	62	64	40	7	6	6.000	1/1	40	
324.0216.11.B	30	ER 25	2-16	35	102,3	32,5	85	62	64	40	7	6	6.000	1/1	40	
424.0220.11.A	40	ER 32	2-20	40	115,5	38	100	72	76	63	9	8	5.000	1/1	70	
424.0220.11.B	40	ER 32	2-20	40	115,5	38	100	72	76	63	9	8	5.000	1/1	70	
524.0226.11.A	50	ER 40	3-26	45	133,5	45	110	92	88	63	13	13	4.000	1/1	100	
524.0226.11.B	50	ER 40	3-26	45	133,5	45	110	92	88	63	13	13	4.000	1/1	100	



Radial Fräskopf Fräsdornaufnahme DIN 6357

Duplomatic DIN 1809

Radial milling head chuck for cutter arbor DIN 6357

Tête de fraisage radiale porte - fraise DIN 6357

Radial Tahrikli Takım Tutucu Alın Kamalı Malafa DIN 6357

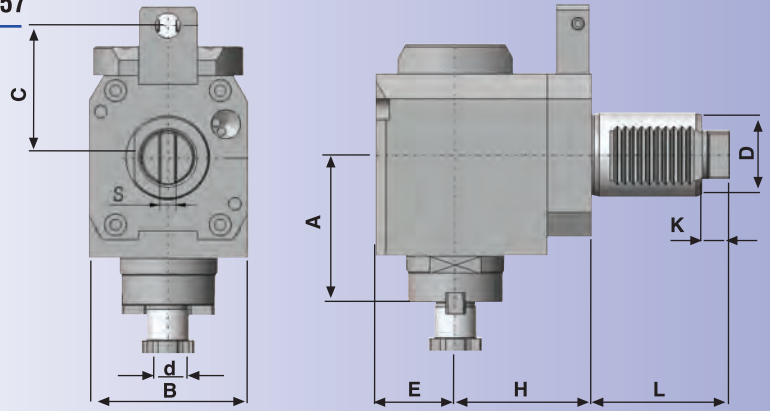

Bestell-Nr. Order Nr. Référence Sipariş Nr.	D	d	A	E	H	L	B	K	S	C	N.Max. (1/min)	i i / i	T.max. (Nm)	Euro
322.1116.11.A	30	16	49	26	55	62	64	7	6	40	6.000	1/1	25	
322.1116.11.B	30	16	49	26	55	62	64	7	6	40	6.000	1/1	25	
422.1116.11.A	40	16	64	38	65	72	76	9	8	63	6.000	1/1	50	
422.1116.11.B	40	16	64	38	65	72	76	9	8	63	6.000	1/1	50	
422.1122.11.A	40	22	64	38	65	72	76	9	8	63	6.000	1/1	50	
422.1122.11.B	40	22	64	38	65	72	76	9	8	63	6.000	1/1	50	
522.1122.11.A	50	22	71	44	75	92	88	13	13	70	5.000	1/1	80	
522.1122.11.B	50	22	71	44	75	92	88	13	13	70	5.000	1/1	80	
522.1127.11.A	50	27	71	44	75	92	88	13	13	70	5.000	1/1	80	
522.1127.11.B	50	27	71	44	75	92	88	13	13	70	5.000	1/1	80	



Axial drilling - milling head collet chuck DIN 6499

Tetê de percage - fraisage axiale mandrin pour pinces DIN 6499

Axial Tahrikli Takım Tutucu Pens Başlığı DIN 6499

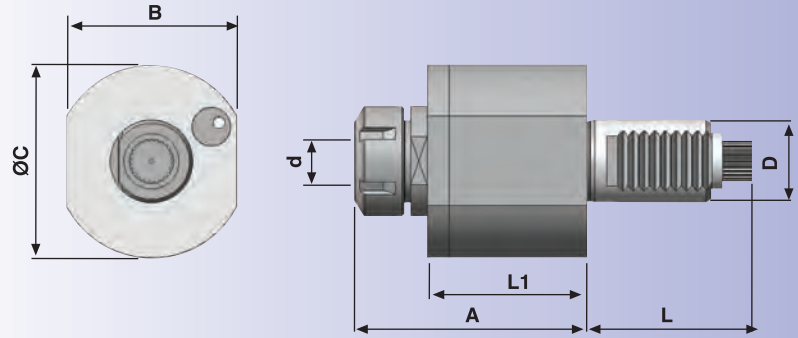

Bestell-Nr. Order Nr. Référence Sipariş Nr.	D	Spannzangen Collet Pincas Pens	d	A	L	L1	B	Ø C	N.Max. (1/min)	i i / i	T.max. (Nm)	Euro
331.0216.11	30	ER 25	2-16	89	67	58	62	70	6.000	1/1	25	
431.0220.11	40	ER 32	2-20	112,5	75	76	76	94	6.000	1/1	50	
431.0226.11	40	ER 40	3-26	126,5	75	76	76	94	6.000	1/1	50	
531.0220.11	50	ER 32	2-20	117,5	93	80	88	102	5.000	1/1	80	
531.0226.11	50	ER 40	3-26	122	93	80	88	102	5.000	1/1	80	

Axial Fräskopf Fräsdornaufnahme DIN 6357

Sauter - Revolver DIN 5480

Axial milling head chuck for cutter arbor DIN 6357

Tetê de fraisage axiale porte - fraise DIN 6357

Axial Tahrikli Takım Tutucu Alın Kamalı Malafa DIN 6357

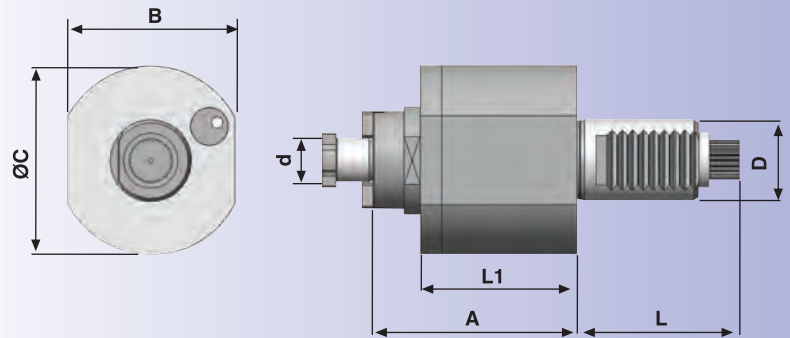

Bestell-Nr. Order Nr. Référence Sipariş Nr.	D	d	A	L	L1	B	Ø C	N.Max. (1/min)	i i / i	T.max. (Nm)	Euro
331.1116.11	30	16	71	67	58	62	70	6.000	1/1	25	
431.1116.11	40	16	104,5	75	76	76	94	6.000	1/1	50	
431.1122.11	40	22	104,5	75	76	76	94	6.000	1/1	50	
531.1122.11	50	22	95	93	80	88	102	5.000	1/1	80	
531.1127.11	50	27	96	93	80	88	102	5.000	1/1	80	

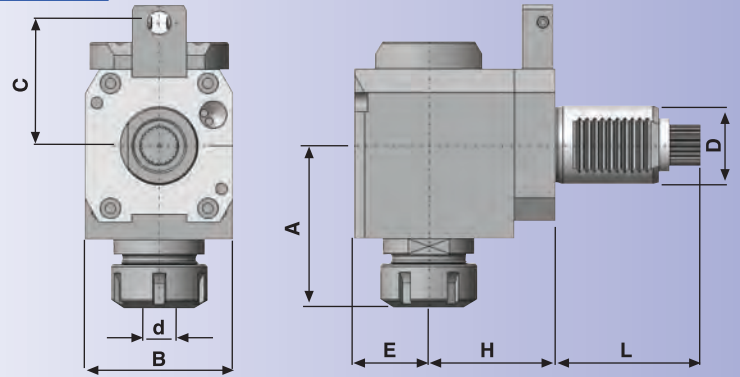
**Radial Bohr - und Fräskopf Spannzangenaufnahme DIN 6499****Sauter - Revolver DIN 5480****Radial drilling - milling head collet chuck DIN 6499****Tetê de perçage - fraisage radiale mandrin pour pinces DIN 6499****Radial Tahrikli Takım Tutucu Pens Başlığı DIN 6499**

Bestell-Nr. Order Nr. Référence Sipariş Nr.	D	Spannzangen Collet Pinces Pens	d	A	E	H	L	B	C	N.Max. (1/min)	i i / i	T.max. (Nm)	Euro
332.0216.11.A	30	ER 25	2-16	67	26	55	67	64	40	6.000	1/1	25	
332.0216.11.B	30	ER 25	2-16	67	26	55	67	64	40	6.000	1/1	25	
432.0220.11.A	40	ER 32	2-20	85	38	65	75	76	63	6.000	1/1	50	
432.0220.11.B	40	ER 32	2-20	85	38	65	75	76	63	6.000	1/1	50	
432.0226.11.A	40	ER 40	3-26	98	38	65	75	76	63	6.000	1/1	50	
432.0226.11.B	40	ER 40	3-26	98	38	65	75	76	63	6.000	1/1	50	
532.0220.11.A	50	ER 32	2-20	92,5	44	75	93	88	70	5.000	1/1	80	
532.0220.11.B	50	ER 32	2-20	92,5	44	75	93	88	70	5.000	1/1	80	
532.0226.11.A	50	ER 40	3-26	98	44	75	93	88	70	5.000	1/1	80	
532.0226.11.B	50	ER 40	3-26	98	44	75	93	88	70	5.000	1/1	80	

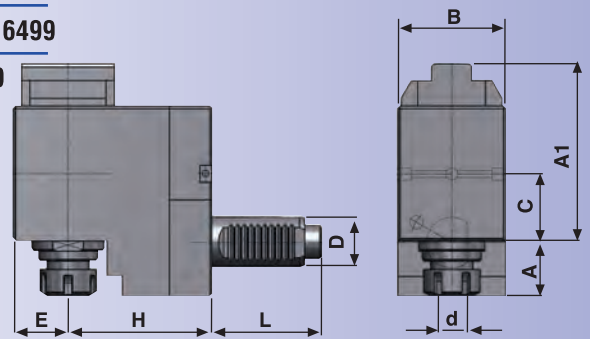
Radial Bohr - und Fräskopf Spannzangenaufnahme-versetzt DIN 6499 Sauter - Revolver DIN 5480**Radial drilling - milling head collet chuck - shifted DIN 6499****Tetê de perçage - fraisage radiale mandrin pour pinces- décalé DIN 6499****Radial Tahrikli Takım Tutucu Pens Başlığı - eksenden kaçık DIN 6499**

Bestell-Nr. Order Nr. Référence Sipariş Nr.	D	Spannzangen Collet Pinces Pens	d	A	A1	E	H	L	B	C	N.Max. (1/min)	i i / i	T.max. (Nm)	Euro
334.0216.11.A	30	ER 25	2-16	35	102,3	33	85	67	64	48	6.000	1/1	40	
334.0216.11.B	30	ER 25	2-16	35	102,3	33	85	67	64	48	6.000	1/1	40	
434.0220.11.A	40	ER 32	2-20	40	115,5	38	100	75	76	56	5.000	1/1	70	
434.0220.11.B	40	ER 32	2-20	40	115,5	38	100	75	76	56	5.000	1/1	70	
534.0226.11.A	50	ER 40	3-26	45	122,2	45	110	93	88	64	4.000	1/1	100	
534.0226.11.B	50	ER 40	3-26	45	122,2	45	110	93	88	64	4.000	1/1	100	



Radial milling head chuck for cutter arbor DIN 6357

Tête de fraise radiale porte - fraise DIN 6357

Radial Tahrikli Takım Tutucu Alın Kamalı Malafa DIN 6357

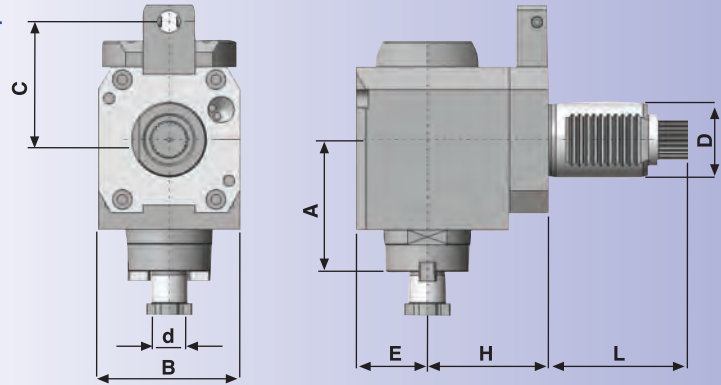

Bestell-Nr. Order Nr. Référence Sipariş Nr.	D	d	A	E	H	L	B	C	N.Max. (1/min)	i i / i	T.max. (Nm)	Euro
332.1116.11.A	30	16	49	26	55	67	64	40	6.000	1/1	25	
332.1116.11.B	30	16	49	26	55	67	64	40	6.000	1/1	25	
432.1116.11.A	40	16	64	38	65	75	76	63	6.000	1/1	50	
432.1116.11.B	40	16	64	38	65	75	76	63	6.000	1/1	50	
432.1122.11.A	40	22	64	38	65	75	76	63	6.000	1/1	50	
432.1122.11.B	40	22	64	38	65	75	76	63	6.000	1/1	50	
532.1122.11.A	50	22	71	44	75	93	88	70	5.000	1/1	80	
532.1122.11.B	50	22	71	44	75	93	88	70	5.000	1/1	80	
532.1127.11.A	50	27	71	44	75	93	88	70	5.000	1/1	80	
532.1127.11.B	50	27	71	44	75	93	88	70	5.000	1/1	80	



Axial Bohr - und Fräskopf Spannzangenaufnahme DIN 6499

Sauter - Revolver DIN 5482

Axial drilling - milling head collet chuck DIN 6499

Tête de perçage - fraisage axiale mandrin pour pinces DIN 6499

Axial Tahrikli Takım Tutucu Pens Başlığı DIN 6499

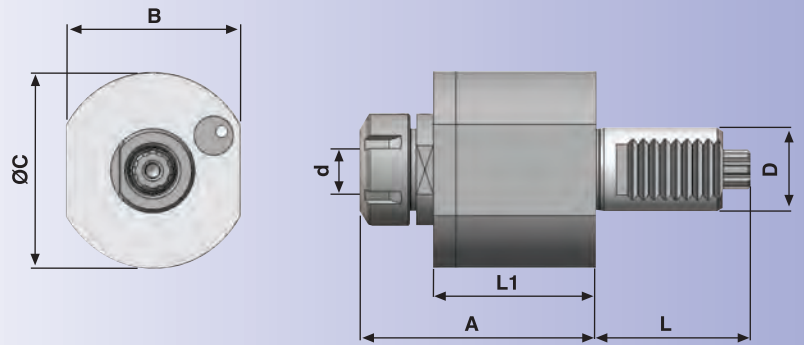

Bestell-Nr. Order Nr. Référence Sipariş Nr.	D	Spannzangen Collet Pincas Pens	d	A	L	L1	B	Ø C	N.Max. (1/min)	i i / i	T.max. (Nm)	Euro
341.0216.11	30	ER 25	2-16	89	55	58	62	70	6.000	1/1	25	
441.0220.11	40	ER 32	2-20	112,5	63	76	76	94	6.000	1/1	50	
441.0226.11	40	ER 40	3-26	126,5	63	76	76	94	6.000	1/1	50	
541.0220.11	50	ER 32	2-20	117,5	93	80	88	102	5.000	1/1	80	
541.0226.11	50	ER 40	3-26	122	93	80	88	102	5.000	1/1	80	

Axial Fräskopf Fräsdornaufnahme DIN 6357

Sauter - Revolver DIN 5482

Axial milling head chuck for cutter arbor DIN 6357

Tête de fraisage axiale porte - fraise DIN 6357

Axial Tahrikli Takım Tutucu Alın Kamalı Malafa DIN 6357

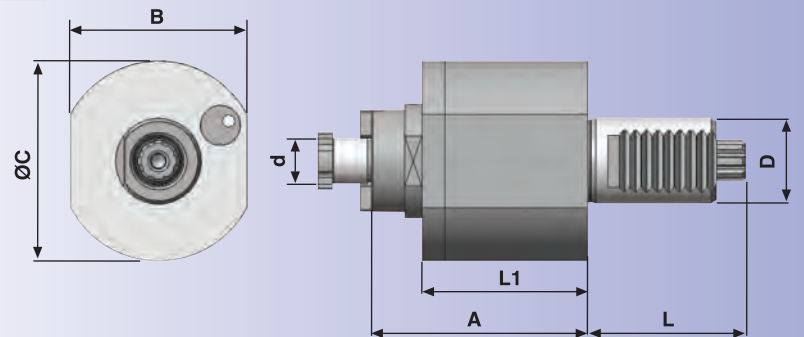

Bestell-Nr. Order Nr. Référence Sipariş Nr.	D	d	A	L	L1	B	Ø C	N.Max. (1/min)	i i / i	T.max. (Nm)	Euro
341.1116.11	30	16	71	55	58	62	70	6.000	1/1	25	
441.1116.11	40	16	104,5	63	76	76	94	6.000	1/1	50	
441.1122.11	40	22	104,5	63	76	76	94	6.000	1/1	50	
541.1122.11	50	22	95	93	80	88	102	5.000	1/1	80	
541.1127.11	50	27	96	93	80	88	102	5.000	1/1	80	



Radial drilling - milling head collet chuck DIN 6499

Tête de perçage - fraisage radiale mandrin pour pinces DIN 6499

Radial Tahrikli Takım Tutucu Pens Başlığı DIN 6499

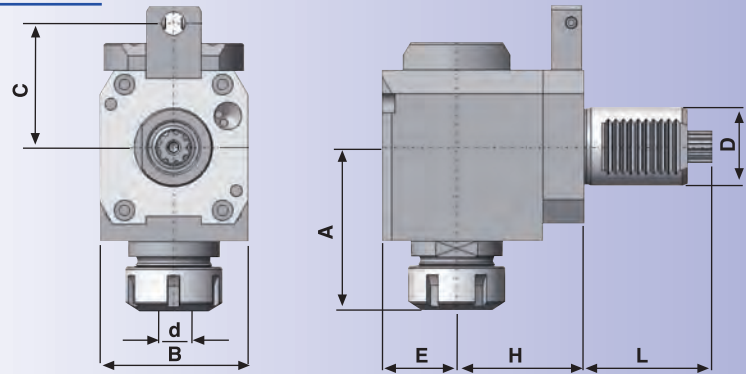

Bestell-Nr. Order Nr. Référence Sipariş Nr.	D	Spannzangen Collet Pincas Pens	d	A	E	H	L	B	C	N.Max. (1/min)	i i / i	T.max. (Nm)	Euro
342.0216.11.A	30	ER 25	2-16	67	26	55	55	64	40	6.000	1/1	25	
342.0216.11.B	30	ER 25	2-16	67	26	55	55	64	40	6.000	1/1	25	
442.0220.11.A	40	ER 32	2-20	85	38	65	63	76	63	6.000	1/1	50	
442.0220.11.B	40	ER 32	2-20	85	38	65	63	76	63	6.000	1/1	50	
442.0226.11.A	40	ER 40	3-26	98	38	65	63	76	63	6.000	1/1	50	
442.0226.11.B	40	ER 40	3-26	98	38	65	63	76	63	6.000	1/1	50	
542.0220.11.A	50	ER 32	2-20	92,5	44	75	93	88	70	5.000	1/1	80	
542.0220.11.B	50	ER 32	2-20	92,5	44	75	93	88	70	5.000	1/1	80	
542.0226.11.A	50	ER 40	3-26	98	44	75	93	88	70	5.000	1/1	80	
542.0226.11.B	50	ER 40	3-26	98	44	75	93	88	70	5.000	1/1	80	

Radial Bohr - und Fräskopf Spannzangenaufnahme-versetzt DIN 6499 Sauter - Revolver DIN 5482

Radial drilling - milling head collet chuck - shifted DIN 6499

Tête de perçage - fraisage radiale mandrin pour pinces - décalé DIN 6499

Radial Tahrikli Takım Tutucu Pens Başlığı - eksenden kaçık DIN 6499

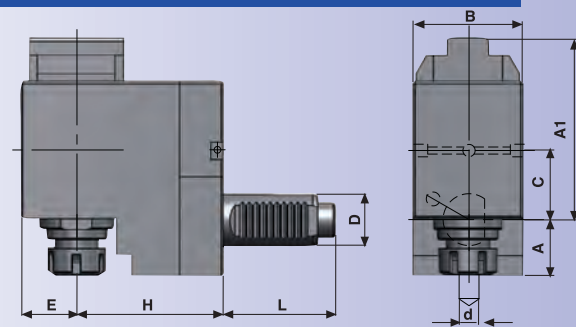

Bestell-Nr. Order Nr. Référence Sipariş Nr.	D	Spannzangen Collet Pincas Pens	d	A	A1	E	H	L	B	C	N.Max. (1/min)	i i / i	T.max. (Nm)	Euro
344.0216.11.A	30	ER 25	2-16	35	102,3	30	76	55	64	40	6.000	1/1	25	
344.0216.11.B	30	ER 25	2-16	35	102,3	30	76	55	64	40	6.000	1/1	25	
444.0220.11.A	40	ER 32	2-20	40	115,5	38	100	63	76	63	5.000	1/1	70	
444.0220.11.B	40	ER 32	2-20	40	115,5	38	100	63	76	63	5.000	1/1	70	
544.0226.11.A	50	ER 40	3-26	45	133,5	45	110	93	88	70	4.000	1/1	100	
544.0226.11.B	50	ER 40	3-26	45	133,5	45	110	93	88	70	4.000	1/1	100	



Radial Fräskopf Fräsdornaufnahme DIN 6357

Sauter - Revolver DIN 5842

Radial milling head chuck for cutter arbor DIN 6357

Tetê de fraisage radiale porte - fraisage DIN 6357

Radial Tahrikli Takım Tutucu Alın Kamalı Malafa DIN 6357

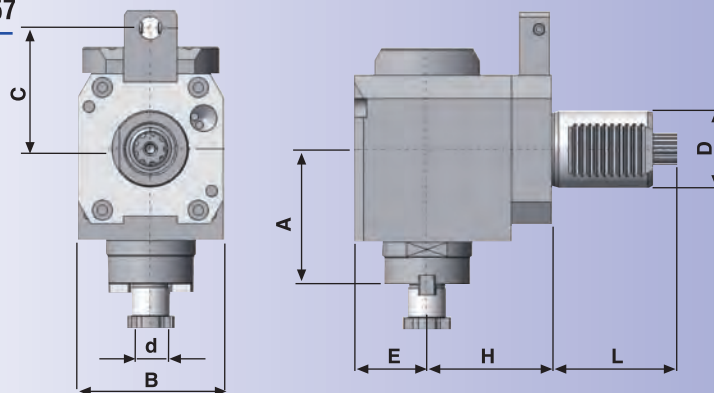

Bestell-Nr. Order Nr. Référence Sipariş Nr.	D	d	A	E	H	L	B	C	N.Max. (1/min)	i i / i	T.max. (Nm)	Euro
342.1116.11.A	30	16	49	26	55	55	64	40	6.000	1/1	25	
342.1116.11.B	30	16	49	26	55	55	64	40	6.000	1/1	25	
442.1116.11.A	40	16	64	38	65	63	76	63	6.000	1/1	50	
442.1116.11.B	40	16	64	38	65	63	76	63	6.000	1/1	50	
442.1122.11.A	40	22	64	38	65	63	76	63	6.000	1/1	50	
442.1122.11.B	40	22	64	38	65	63	76	63	6.000	1/1	50	
542.1122.11.A	50	22	71	44	75	93	88	70	5.000	1/1	80	
542.1122.11.B	50	22	71	44	75	93	88	70	5.000	1/1	80	
542.1127.11.A	50	27	71	44	75	93	88	70	5.000	1/1	80	
542.1127.11.B	50	27	71	44	75	93	88	70	5.000	1/1	80	



Axial drilling - milling head collet chuck DIN 6499

Tetê de percage - fraisage axiale mandrin pour pinces DIN 6499

Axial Tahrikli Takım Tutucu Pens Başlığı DIN 6499

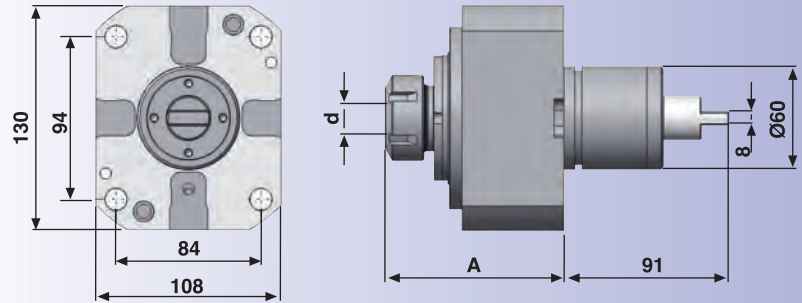

Bestell-Nr. Order Nr. Référence Sipariş Nr.	Spannzangen Collet Pinces Pens	d	A	N.Max. (1/min)	i i / i	T.max. (Nm)	Euro
451.0220.11	ER 32	2-20	96	6.000	1/1	100	
451.0226.11	ER 40	3-26	100	6.000	1/1	100	

Axial Fräskopf Fräsdornaufnahme DIN 6357

Axial milling head chuck for cutter arbor DIN 6357

Tetê de fraisage axiale porte - fraisage DIN 6357

Axial Tahrikli Takım Tutucu Alın Kamalı Malafa DIN 6357

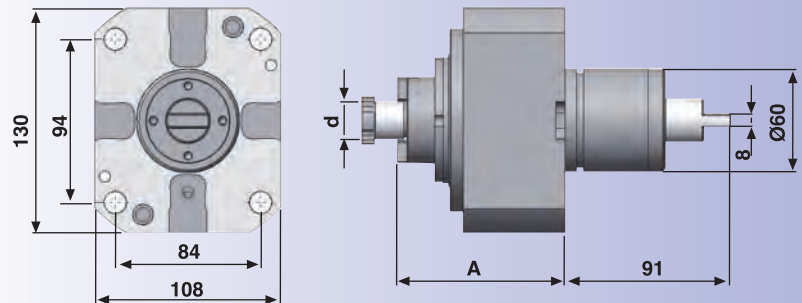

Bestell-Nr. Order Nr. Référence Sipariş Nr.	d	A	N.Max. (1/min)	i i / i	T.max. (Nm)	Euro
451.1122.11	22	74	6.000	1/1	100	
451.1127.11	27	74	6.000	1/1	100	



Radial Bohr - und Fräskopf Spannzangenaufnahme DIN 6499

Mori Seiki NL - NT

Radial drilling - milling head collet chuck DIN 6499

Tetê de percage - fraisage radiale mandrin pour pinces DIN 6499

Radial Tahrikli Takım Tutucu Pens Başlığı DIN 6499

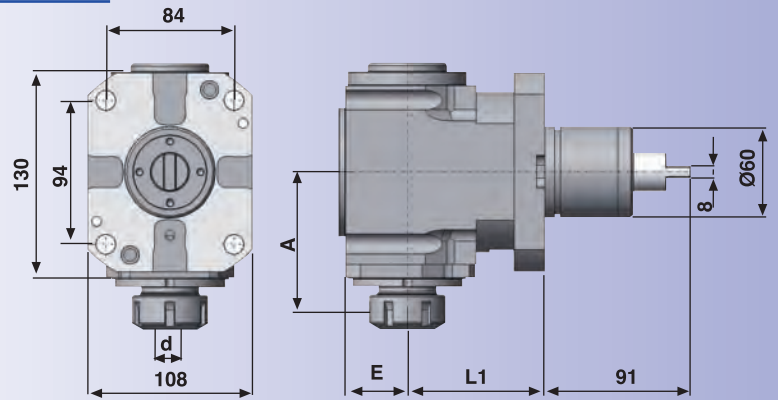

Bestell-Nr. Order Nr. Référence Sipariş Nr.	Spannzangen Collet Pincas Pens	d	A	L1	E	N.Max. (1/min)	i i / i	T.max. (Nm)	Euro
452.0220.11	ER 32	2-20	103,5	90	41	6.000	1/1	100	
452.0226.11	ER 40	2-26	107	90	41	6.000	1/1	100	

Radial Fräskopf Fräsdornaufnahme DIN 6357

Mori Seiki NL - NT

Radial milling head chuck for cutter arbor DIN 6357

Tetê de fraisage radiale porte - fraise DIN 6357

Radial Tahrikli Takım Tutucu Alın Kamalı Malafa DIN 6357

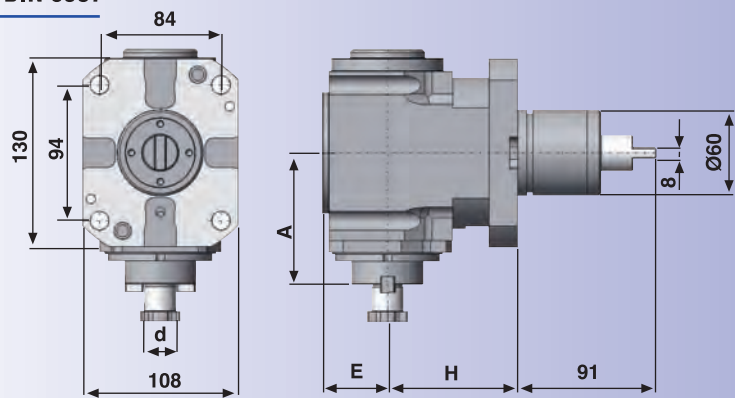

Bestell-Nr. Order Nr. Référence Sipariş Nr.	d	A	H	E	N.Max. (1/min)	i i / i	T.max. (Nm)	Euro
452.1122.11	22	81	90	41	6.000	1/1	100	
452.1127.11	27	82	90	41	6.000	1/1	100	

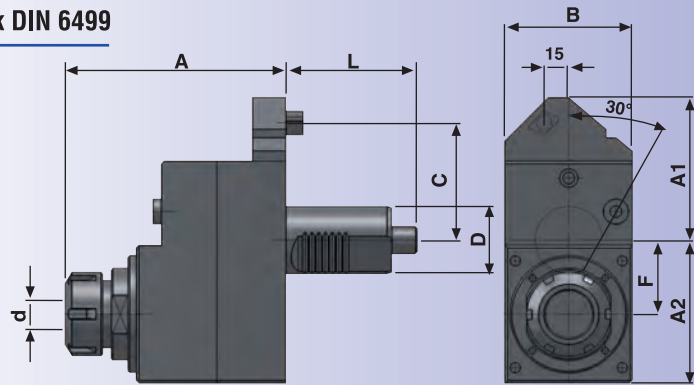
**Axial Bohr - und Fräskopf Spannzangenaufnahme - versetzt DIN 6499****Mazak Nexus 200-250****Axial drilling - milling head collet chuck - shifted DIN 6499****Tetê de perçage - fraisage axiale mandrin pour pinces - décalé DIN 6499****Axial Tahrikli Takım Tutucu Pens Başlığı - eksenden kaçık DIN 6499**

Bestell-Nr. Order Nr. Référence Sipariş Nr.	D	Spannzangen Collet Pince Pens	d	A	A1	A2	L	B	C	F	N.Max. (1/min)	i i / i	T.max. (Nm)	Euro
463.0220.11.B	40	ER 32	2-20	135	82	88	78	76	70	50	6.000	1/1	70	

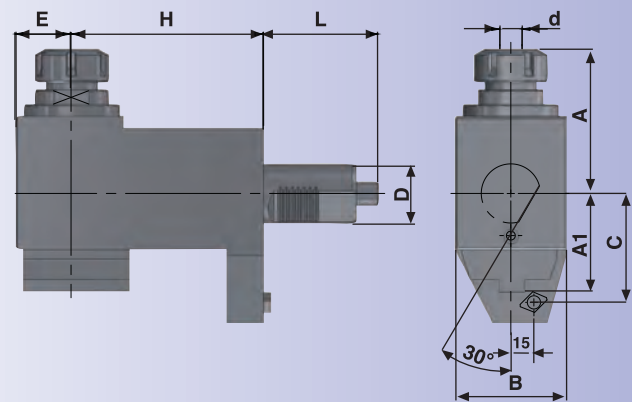
Radial Bohr - und Fräskopf Spannzangenaufnahme DIN 6499**Mazak Nexus 200-250****Radial drilling - milling head collet chuck DIN 6499****Tetê de perçage - fraisage radiale mandrin pour pinces DIN 6499****Radial Tahrikli Takım Tutucu Pens Başlığı DIN 6499**

Bestell-Nr. Order Nr. Référence Sipariş Nr.	D	Spannzangen Collet Pince Pens	d	A	A1	E	H	L	B	C	N.Max. (1/min)	i i / i	T.max. (Nm)	Euro
462.0220.11.B	40	ER 32	2-20	100	66	38	130	77,8	76	70	6.000	1/1	70	

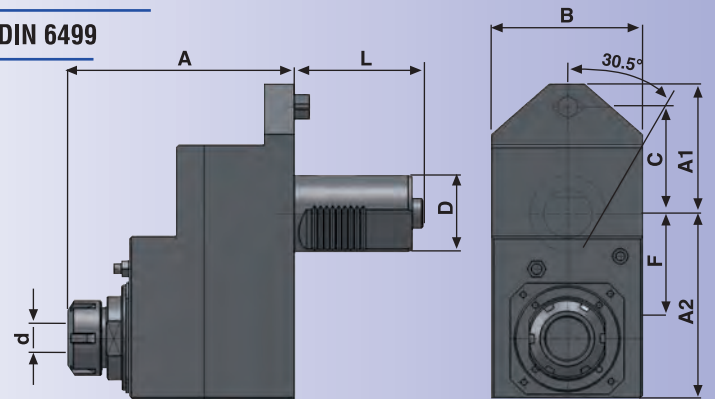
**Axial Bohr - und Fräskopf Spannzangenaufnahme-versetzt DIN 6499****Mazak Nexus 300-350****Axial drilling - milling head collet chuck - shifted DIN 6499****Têté de percage - fraisage axiale mandrin pour pinces- décalé DIN 6499****Axial Tahrikli Takım Tutucu Pens Başlığı - eksenden kaçık DIN 6499**

Bestell-Nr. Order Nr. Référence Sipariş Nr.	D	Spannzangen Collet Pinces Pens	d	A	A1	A2	L	B	C	F	N.Max. (1/min)	i i / i	T.max. (Nm)	Euro
463.0226.11.1B	50	ER 40	3-26	165	85	122	85	100	70	75	4.000	1/1	100	

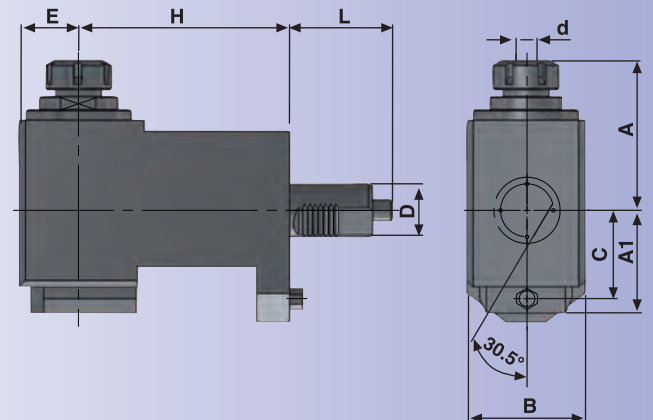
Radial Bohr - und Fräskopf Spannzangenaufnahme DIN 6499**Mazak Nexus 300-350****Radial drilling - milling head collet chuck DIN 6499****Têté de percage - fraisage radiale mandrin pour pinces DIN 6499****Radial Tahrikli Takım Tutucu Pens Başlığı DIN 6499**

Bestell-Nr. Order Nr. Référence Sipariş Nr.	D	Spannzangen Collet Pinces Pens	d	A	A1	E	H	L	B	C	N.Max. (1/min)	i i / i	T.max. (Nm)	Euro
462.0226.11.1B	40	ER 40	3-26	125	77,5	45	160	85	90	70	4.000	1/1	100	

Axial Bohr - und Fräskopf Spannzangenaufnahme DIN 6499

Okuma LB-LT 200-M



Axial drilling - milling head collet chuck DIN 6499

Tête de perçage - fraisage axiale mandrin pour pinces DIN 6499

Axial Tahrikli Takım Tutucu Pens Başlığı DIN 6499

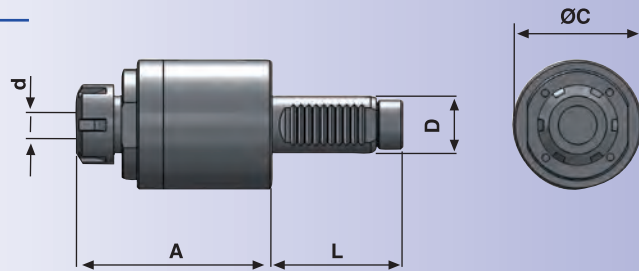

Bestell-Nr. Order Nr. Référence Sipariş Nr.	D	Spannzangen Collet Pinces Pens	d	A	L	Ø C	N.Max. (1/min)	i i / i	T.max. (Nm)	Euro
371.0216.11	30	ER 25	2-16	105	69	68	6.000	1/1	40	

Radial Bohr - und Fräskopf Spannzangenaufnahme DIN 6499

Okuma LT 200 M

Radial drilling - milling head collet chuck DIN 6499

Tête de perçage - fraisage radiale mandrin pour pinces DIN 6499

Radial Tahrikli Takım Tutucu Pens Başlığı DIN 6499

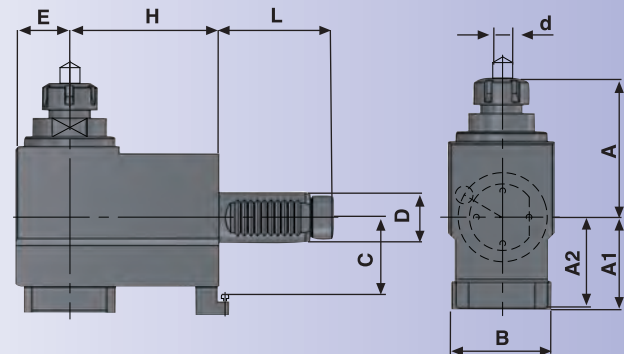

Bestell-Nr. Order Nr. Référence Sipariş Nr.	D	Spannzangen Collet Pinces Pens	d	A	A1	A2	E	H	L	B	C	N.Max. (1/min)	i i / i	T.max. (Nm)	Euro
372.0216.11.B	30	ER 25	2-16	85	58	57,3	32,5	90	69	64	40	6.000	1/1	40	

Radial Bohr - und Fräskopf Spannzangenaufnahme-versetzt DIN 6499

Okuma LB 200 M

Radial drilling - milling head collet chuck - shifted DIN 6499

Tête de perçage - fraisage radiale mandrin pour pinces - décalé DIN 6499

Radial Tahrikli Takım Tutucu Pens Başlığı-eksenden kaçık DIN 6499

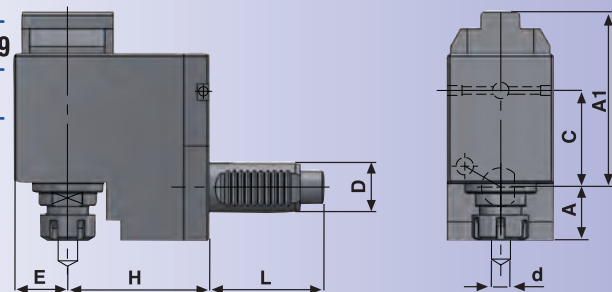

Bestell-Nr. Order Nr. Référence Sipariş Nr.	D	Spannzangen Collet Pinces Pens	d	A	A1	A2	E	H	L	B	C	N.Max. (1/min)	i i / i	T.max. (Nm)	Euro
374.0216.11.A	30	ER 25	2-16	35	102,3	35	32,5	85	69	64	63	6.000	1/1	40	

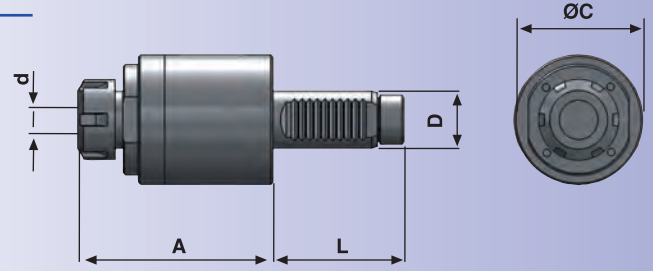
**Axial Bohr - und Fräskopf Spannzangenaufnahme DIN 6499****Okuma LB-LT 300 M****Axial drilling - milling head collet chuck DIN 6499****Tetê de perçage - fraisage axiale mandrin pour pinces DIN 6499****Axial Tahrikli Takım Tutucu Pens Başlığı DIN 6499**

Bestell-Nr. Order Nr. Référence Sipariş Nr.	D	Spannzangen Collet Pincas Pens	d	A	L	Ø C	N.Max. (1/min)	i i / i	T.max. (Nm)	Euro
471.0220.11	40	ER 32	2-20	125	93	83	5.000	1/1	50	

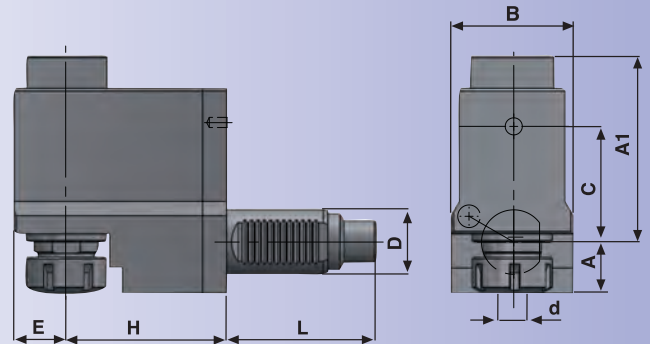
Radial Bohr - und Fräskopf Spannzangenaufnahme DIN 6499**Okuma LT 300 M****Radial drilling - milling head collet chuck DIN 6499****Tetê de perçage - fraisage radiale mandrin pour pinces DIN 6499****Radial Tahrikli Takım Tutucu Pens Başlığı DIN 6499**

Bestell-Nr. Order Nr. Référence Sipariş Nr.	D	Spannzangen Collet Pincas Pens	d	A	A1	E	H	L	B	B1	C	N.Max. (1/min)	i i / i	T.max. (Nm)	Euro
474.0220.11.B	40	ER 32	2-20	100	66	38	90	93	83	76	50	5.000	1/1	70	

Radial Bohr - und Fräskopf Spannzangenaufnahme DIN 6499

Okuma LB 300 M



Radial drilling - milling head collet chuck DIN 6499

Tetê de perçage - fraisage radiale mandrin pour pinces DIN 6499

Radial Tahrikli Takım Tutucu Pens Başlığı DIN 6499

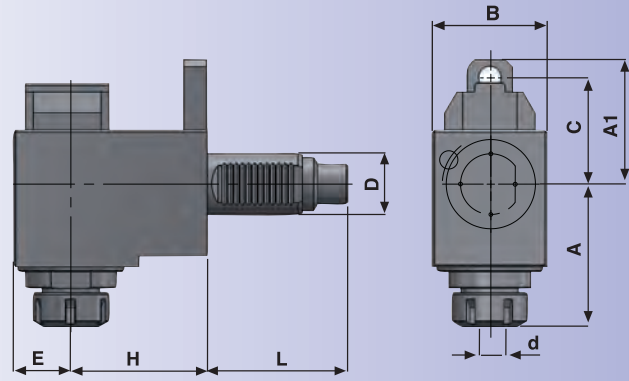

Bestell-Nr. Order Nr. Référence Sipariş Nr.	D	Spannzangen Collet Pince Pens	d	A	A1	E	H	L	B	C	N.Max. (1/min)	i i / i	T.max. (Nm)	Euro
472.0220.11.A	40	ER 32	2-20	100	82	38	90	93	76	70	4.000	1/1	70	

Radial Bohr - und Fräskopf Spannzangenaufnahme-versetzt DIN 6499

Okuma LB 300 M-Radial

Radial drilling - milling head collet chuck - shifted DIN 6499

Tetê de perçage - fraisage radiale mandrin pour pinces - décalé DIN 6499

Radial Tahrikli Takım Tutucu Pens Başlığı-eksenden kaçık DIN 6499

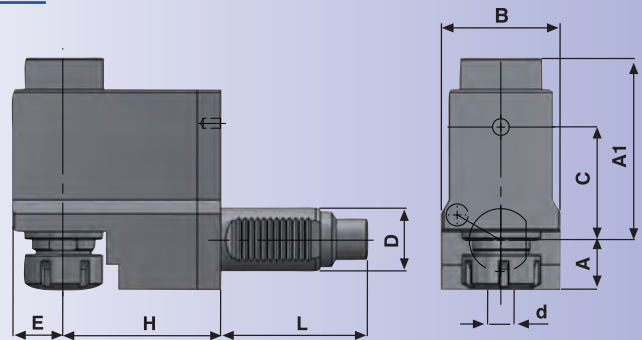

Bestell-Nr. Order Nr. Référence Sipariş Nr.	D	Spannzangen Collet Pince Pens	d	A	A1	E	H	L	B	C	N.Max. (1/min)	i i / i	T.max. (Nm)	Euro
474.0220.11.A	40	ER 32	2-20	40	115,5	38	100	93	76	70	4.000	1/1	70	

**Axial Bohr - und Fräskopf Spannzangenaufnahme DIN 6499****Okuma LB 400-M**

Axial drilling - milling head collet chuck DIN 6499

Tête de perçage - fraise axiale mandrin pour pinces DIN 6499

Axial Tahrikli Takım Tutucu Pens Başlığı DIN 6499

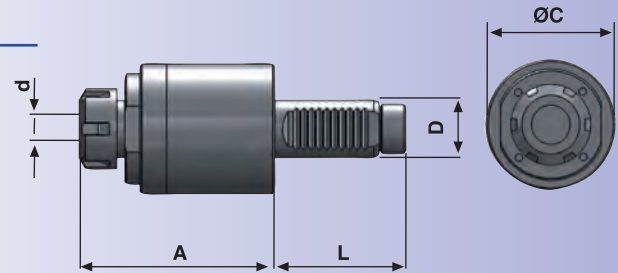

Bestell-Nr. Order Nr. Référence Sipariş Nr.	D	Spannzangen Collet Pincas Pens	d	A	L	Ø C	N.Max. (1/min)	i i / i	T.max. (Nm)	Euro
471.0220.11.1	40	ER 32	2-20	125	101	83	5.000	1/1	50	

Radial Bohr - und Fräskopf Spannzangenaufnahme DIN 6499**Okuma LB 400 M**

Radial drilling - milling head collet chuck DIN 6499

Tête de perçage - fraise radiale mandrin pour pinces DIN 6499

Radial Tahrikli Takım Tutucu Pens Başlığı DIN 6499

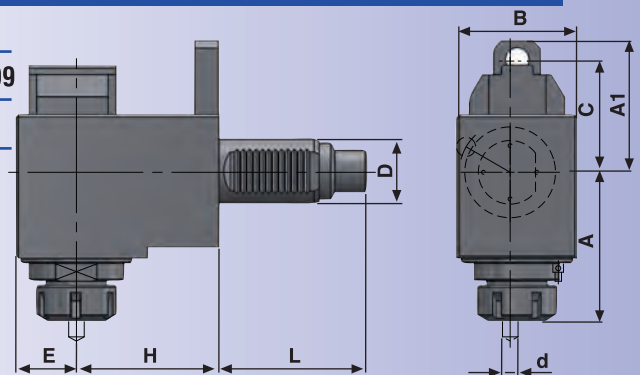

Bestell-Nr. Order Nr. Référence Sipariş Nr.	D	Spannzangen Collet Pincas Pens	d	A	A1	E	H	L	B	C	N.Max. (1/min)	i i / i	T.max. (Nm)	Euro
472.0220.11.1A	40	ER 32	2-20	100	82	38	90	101	76	70	5.000	1/1	70	

Radial Bohr - und Fräskopf Spannzangenaufnahme-versetzt DIN 6499**Okuma LB 400**

Radial drilling - milling head collet chuck - shifted DIN 6499

Tête de perçage - fraise radiale mandrin pour pinces - décalé DIN 6499

Radial Tahrikli Takım Tutucu Pens Başlığı-eksenden kaçık DIN 6499

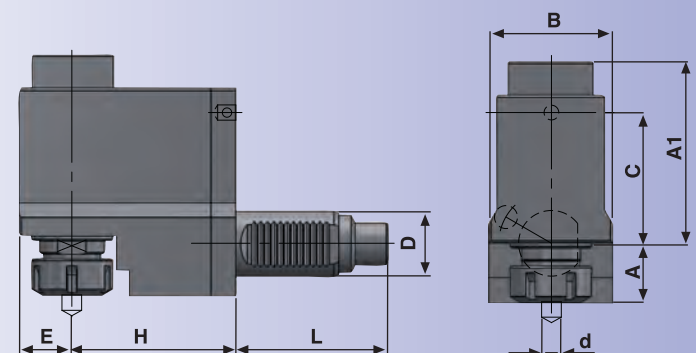

Bestell-Nr. Order Nr. Référence Sipariş Nr.	D	Spannzangen Collet Pincas Pens	d	A	A1	E	H	L	B	C	N.Max. (1/min)	i i / i	T.max. (Nm)	Euro
474.0220.11.1A	40	ER 32	2-20	40	115,5	38	100	101	76	70	5.000	1/1	70	

Axial Bohr - und Fräskopf Spannzangenaufnahme DIN 6499

Okuma LB 2000



Axial drilling - milling head collet chuck DIN 6499

Tetê de perçage - fraisage axiale mandrin pour pinces DIN 6499

Axial Tahrikli Takım Tutucu Pens Başlığı DIN 6499

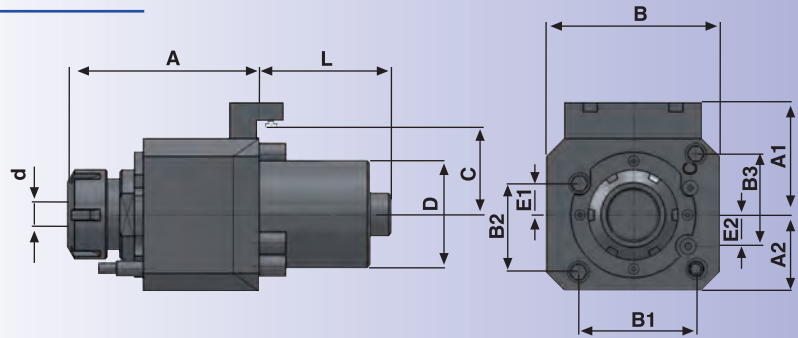

Bestell-Nr. Order Nr. Référence Sipariş Nr.	D	Spannzangen Collet Pinces Pens	d	A	A1	A2	E1	E2	L	B	B1	B2	B3	C	N.Max. (1/min)	i i/i	T.max. (Nm)	Euro
471.0220.11.2	60	ER 32	2-20	95	66	50	26	26	62	97	73	65	65	50	6.000	1/1	70	

Radial Bohr - und Fräskopf Spannzangenaufnahme DIN 6499

Okuma LB 2000

Radial drilling - milling head collet chuck DIN 6499

Tetê de perçage - fraisage radiale mandrin pour pinces DIN 6499

Radial Tahrikli Takım Tutucu Pens Başlığı DIN 6499

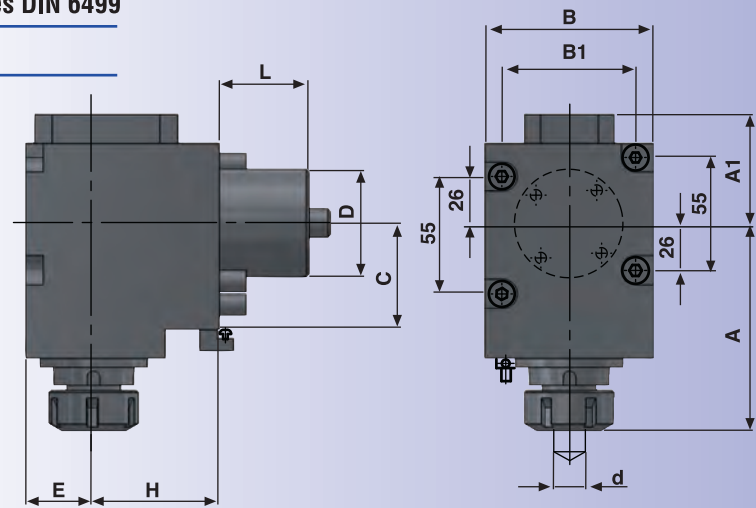

Bestell-Nr. Order Nr. Référence Sipariş Nr.	D	Spannzangen Collet Pinces Pens	d	A	A1	E	H	L	B	B1	C	N.Max. (1/min)	i i/i	T.max. (Nm)	Euro
472.0220.11.2A	60	ER 32	2-20	90	60,5	38	70	62	94	73	50	6.000	1/1	70	

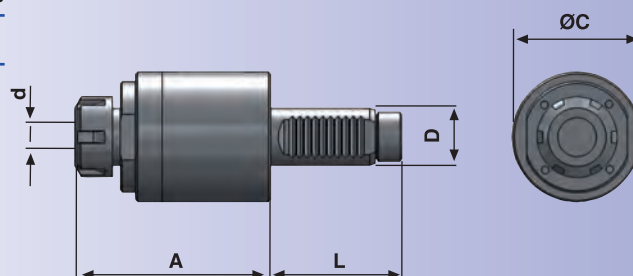
**Axial Bohr - und Fräskopf Spannzangenaufnahme DIN 6499****Okuma LVT 300 M****Axial drilling - milling head collet chuck DIN 6499****Tetê de percage - fraisage axiale mandrin pour pinces DIN 6499****Axial Tahrikli Takım Tutucu Pens Başlığı DIN 6499**

Bestell-Nr. Order Nr. Référence Sipariş Nr.	D	Spannzangen Collet Pincas Pens	d	A	L	Ø C	N.Max. (1/min)	i i / i	T.max. (Nm)	Euro
471.0220.11	40	ER 32	2-20	125	93	83	5.000	1/1	50	

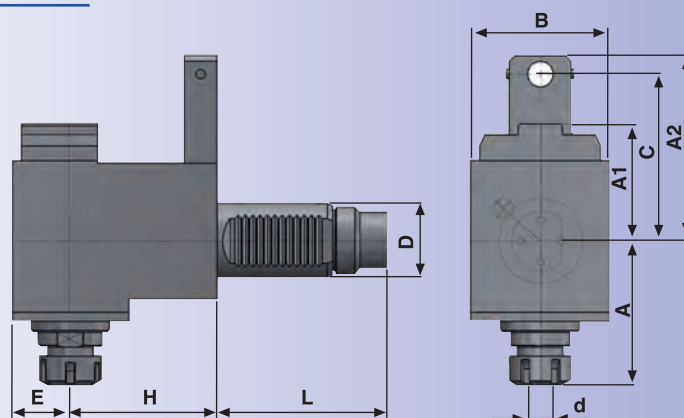
Radial Bohr - und Fräskopf Spannzangenaufnahme DIN 6499**Okuma LVT 300 M****Radial drilling - milling head collet chuck DIN 6499****Tetê de percage - fraisage radiale mandrin pour pinces DIN 6499****Radial Tahrikli Takım Tutucu Pens Başlığı DIN 6499**

Bestell-Nr. Order Nr. Référence Sipariş Nr.	D	Spannzangen Collet Pincas Pens	d	A	A1	A2	E	H	L	B	C	N.Max. (1/min)	i i / i	T.max. (Nm)	Euro
472.0220.11.3A	40	ER 32	2-20	100	66	102	38	90	93	76	90	5.000	1/1	70	

Axial Bohr - und Fräskopf Spannzangenaufnahme DIN 6499

Okuma LB 4000



Axial drilling - milling head collet chuck DIN 6499

Têté de perçage - fraisage axiale mandrin pour pinces DIN 6499

Axial Tahrikli Takım Tutucu Pens Başlığı DIN 6499

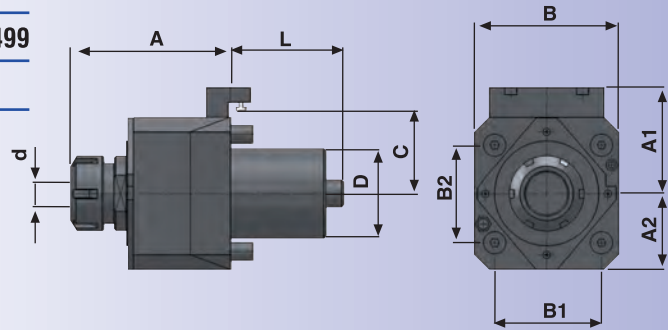

Bestell-Nr. Order Nr. Référence Sipariş Nr.	D	Spannzangen Collet Pincas Pens	d	A	A1	A2	L	B	B1	B2	C	N.Max. (1/min)	i i/i	T.max. (Nm)	Euro
471.0226.11.4	60	ER 40	3-26	100	71	55	76	114	78	80	55	6.000	1/1	100	

Radial Bohr - und Fräskopf Spannzangenaufnahme DIN 6499

Okuma LB 4000

Radial drilling - milling head collet chuck DIN 6499

Têté de perçage - fraisage radiale mandrin pour pinces DIN 6499

Radial Tahrikli Takım Tutucu Pens Başlığı DIN 6499

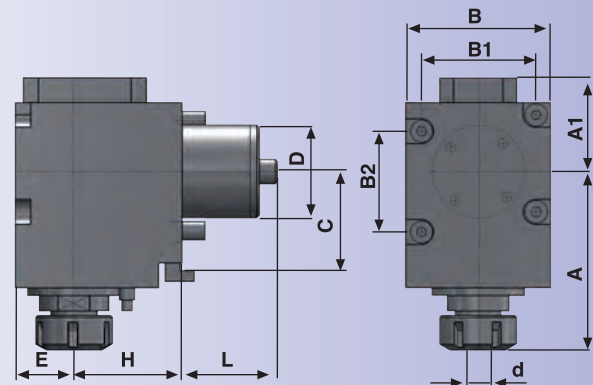

Bestell-Nr. Order Nr. Référence Sipariş Nr.	D	Spannzangen Collet Pincas Pens	d	A	A1	E	H	L	B	B1	B2	C	N.Max. (1/min)	i i/i	T.max. (Nm)	Euro
472.0226.11.4A	60	ER 40	3-26	140	71	45	85	76	99	78	80	55	6.000	1/1	70	

Axial Bohr - und Fräskopf Spannzangenaufnahme DIN 6499

Doosan BMT 45-55-65-75

Axial drilling - milling head collet chuck DIN 6499

Têté de perçage - fraisage axiale mandrin pour pinces DIN 6499

Axial Tahrikli Takım Tutucu Pens Başlığı DIN 6499

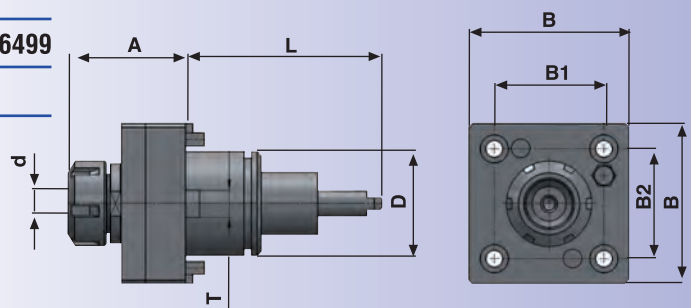

Bestell-Nr. Order Nr. Référence Sipariş Nr.	D	Spannzangen Collet Pincas Pens	BMT	d	A	L	T	B	B1	B2	N.Max. (1/min)	i i/i	T.max. (Nm)	Euro
611.0216.11	45	ER 25	45	2-16	68	84	-	75	58	58	6.000	1/1	25	
611.0216.11.1	55	ER 25	55	2-16	70	104	15	85	64	64	6.000	1/1	40	
611.0220.11.2	65	ER 32	65	2-20	85	112	18	94	73	70	4.000	1/1	70	
611.0226.11.3	75	ER 40	75	3-26	115	110	25	112	90	90	3.000	1/1	100	

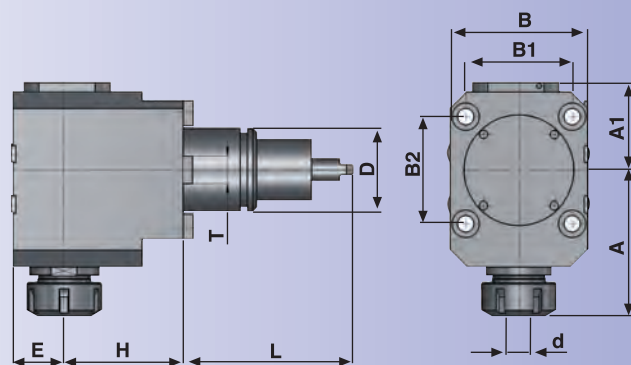
**Radial Bohr - und Fräskopf Spannzangenaufnahme DIN 6499****Doosan BMT 45-55-65-75****Radial drilling - milling head collet chuck DIN 6499****Tetê de perçage - fraisage radiale mandrin pour pinces DIN 6499****Radial Tahrikli Takım Tutucu Pens Başlığı DIN 6499**

Bestell-Nr. Order Nr. Référence Sipariş Nr.	D	Spannzangen Collet Pinces Pens	BMT	d	A	A1	E	H	L	T	B	B1	B2	N.Max. (1/min)	i i/i	T.max. (Nm)	Euro
612.0216.11	45	ER 25	45	2-16	90	56,7	28,5	65	84	15	75	58	58	6.000	1/1	25	
612.0216.11.1	55	ER 25	55	2-16	102	59,5	34	70	104	15	85	64	64	6.000	1/1	40	
612.0220.11.2	65	ER 32	65	2-20	112	59,5	38	72	112	18	94	73	70	4.000	1/1	70	
612.0226.11.3	75	ER 40	75	3-26	138	71	47	60	110	25	112	90	90	3.000	1/1	100	

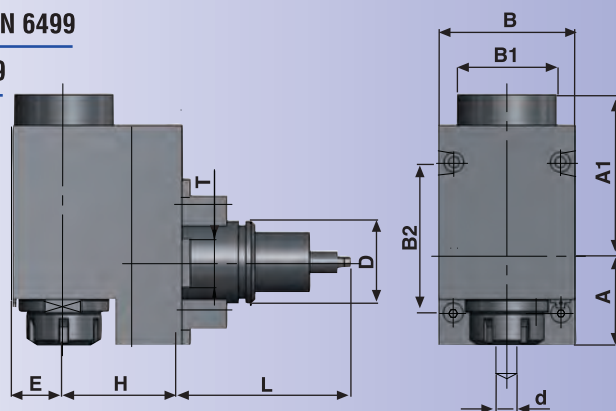
Radial Bohr - und Fräskopf Spannzangenaufnahme-versetzt DIN 6499**Doosan BMT 55-65****Radial drilling - milling head collet chuck - shifted DIN 6499****Tetê de perçage - fraisage radiale mandrin pour pinces - décalé DIN 6499****Radial Tahrikli Takım Tutucu Pens Başlığı -eksenden kaçık DIN 6499**

Bestell-Nr. Order Nr. Référence Sipariş Nr.	D	Spannzangen Collet Pinces Pens	BMT	d	A	A1	E	H	L	T	B	B1	B2	N.Max. (1/min)	i i/i	T.max. (Nm)	Euro
614.0216.11.1A	55	ER 25	55	2-16	42,5	95,5	36	70	104	-	85	64	64	6.000	1/1	40	
614.0220.11.2A	65	ER 32	65	2-20	55	93	38	86	112	18	94	73	70	4.000	1/1	70	



Axial Bohr - und Fräskopf Spannzangenaufnahme DIN 6499 Goodway GS 200 / 260 / 280 M-ML-LMS

Axial drilling - milling head collet chuck DIN 6499

Tetê de perçage - fraisage axiale mandrin pour pinces DIN 6499

Axial Tahrikli Takım Tutucu Pens Başlığı DIN 6499

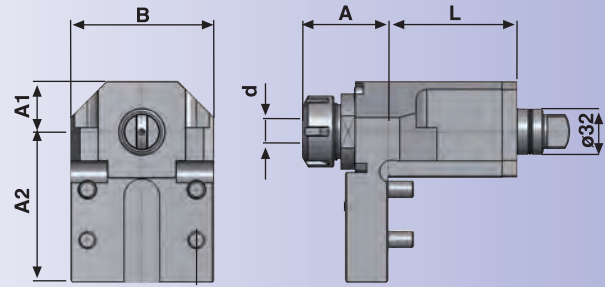

Bestell-Nr. Order Nr. Référence Sipariş Nr.	Spannzangen Collet Pinces Pens	d	A	A1	A2	L	B	N.Max. (1/min)	i i / i	T.max. (Nm)	Euro
621.0220.11	ER 32	2-20	60	35	105	90	100	6.000	1/1	50	

Radial Bohr - und Fräskopf Spannzangenaufnahme DIN 6499 Goodway GS 200 / 260 / 280 M-ML-LMS

Radial drilling - milling head collet chuck DIN 6499

Tetê de perçage - fraisage radiale mandrin pour pinces DIN 6499

Radial Tahrikli Takım Tutucu Pens Başlığı DIN 6499

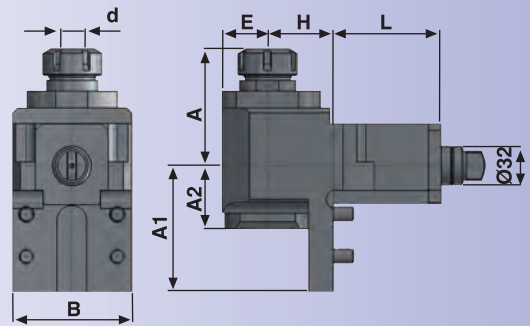

Bestell-Nr. Order Nr. Référence Sipariş Nr.	Spannzangen Collet Pinces Pens	d	A	A1	A2	E	H	L	B	N.Max. (1/min)	i i / i	T.max. (Nm)	Euro
622.0220.11	ER 32	2-20	97,5	105	53	38	55	90	100	4.000	1/1	50	



Axial Bohr - und Fräskopf Spannzangenaufnahme DIN 6499 Takisawa EX 308 / EX 310 / EX 508 / EX 510

Axial drilling - milling head collet chuck DIN 6499

Tetê de perçage - fraisage axiale mandrin pour pinces DIN 6499

Axial Tahrikli Takım Tutucu Pens Başlığı DIN 6499

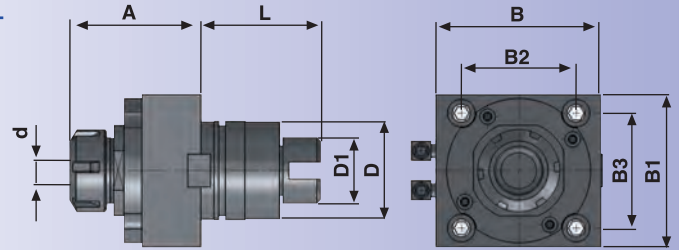

Bestell-Nr. Order Nr. Référence Sipariş Nr.	Spannzangen Collet Pinces Pens	d	D	D1	A	L	B	B1	B2	B3	N.Max. (1/min)	i i / i	T.max. (Nm)	Euro
631.0220.11.1	ER 32	2-20	60	40	80	75	100	92	70	70	4.000	1/1	50	

Radial Bohr - und Fräskopf Spannzangenaufnahme DIN 6499 Takisawa EX 308 / EX 310 / EX 508 / EX 510

Radial drilling - milling head collet chuck DIN 6499

Tetê de perçage - fraisage radiale mandrin pour pinces DIN 6499

Radial Tahrikli Takım Tutucu Pens Başlığı DIN 6499

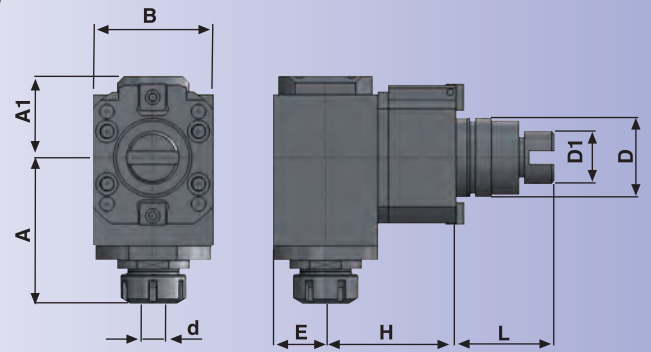

Bestell-Nr. Order Nr. Référence Sipariş Nr.	Spannzangen Collet Pinces Pens	d	D	D1	A	A1	E	H	L	B	N.Max. (1/min)	i i / i	T.max. (Nm)	Euro
632.0220.11.1	ER 32	2-20	60	40	111,5	57	40	90	75	92	6.000	1/1	50	



Axial Bohr - und Fräskopf Spannzangenaufnahme DIN 6499 Takisawa EX 308 / EX 310 / EX 508 / EX 510

Axial drilling - milling head collet chuck DIN 6499

Tetê de perçage - fraisage axiale mandrin pour pinces DIN 6499

Axial Tahrikli Takım Tutucu Pens Başlığı DIN 6499

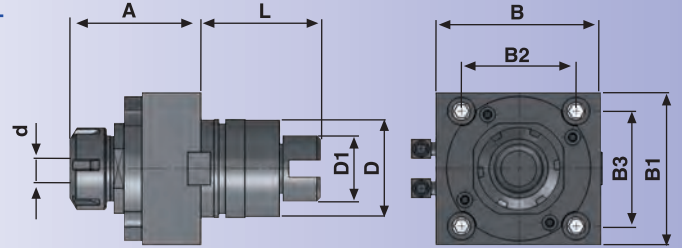

Bestell-Nr. Order Nr. Référence Sipariş Nr.	Spannzangen Collet Pinces Pens	d	D	D1	A	L	B	B1	B2	B3	N.Max. (1/min)	i i / i	T.max. (Nm)	Euro
631.0220.11.1	ER 32	2-20	60	40	80	75	100	92	70	70	4.000	1/1	50	

Radial Bohr - und Fräskopf Spannzangenaufnahme DIN 6499 Takisawa EX 308 / EX 310 / EX 508 / EX 510

Radial drilling - milling head collet chuck DIN 6499

Tetê de perçage - fraisage radiale mandrin pour pinces DIN 6499

Radial Tahrikli Takım Tutucu Pens Başlığı DIN 6499

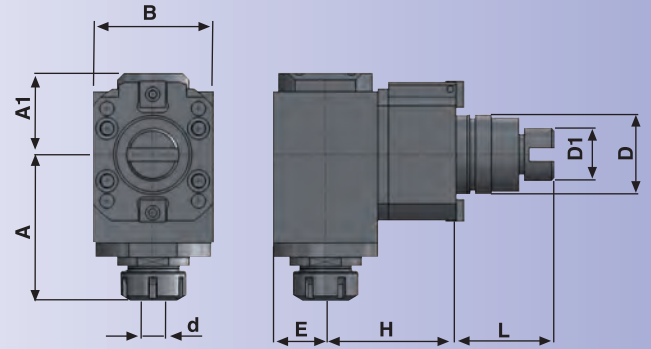

Bestell-Nr. Order Nr. Référence Sipariş Nr.	Spannzangen Collet Pinces Pens	d	D	D1	A	A1	E	H	L	B	N.Max. (1/min)	i i / i	T.max. (Nm)	Euro
632.0220.11.1	ER 32	2-20	60	40	111,5	57	40	90	75	92	6.000	1/1	50	