



HNANÉ UPÍNAČE PRE CNC STROJE

HAAS BMT 65
HAAS BMT 65
HAAS BMT 65



Made in Germany

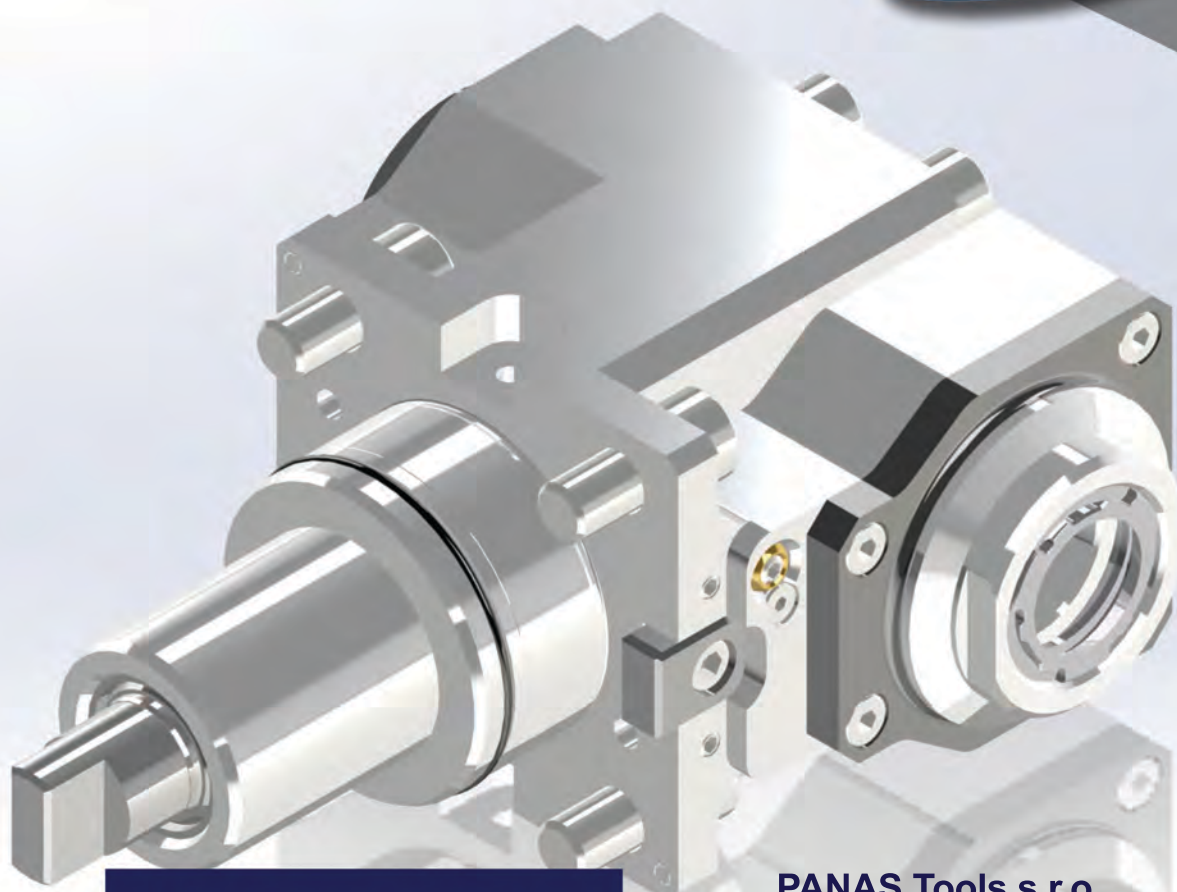

PANAS Tools s.r.o.
Hradište č. 371, SK - 958 54
Tel. : +421/38/749 67 64 - 5
www.panas.sk, info@panas.sk

Netto-Preise für die Industrie (nicht rabattfähig)
Net prices for the industry (not discountable)
Prix nets pour l'industrie (ne pas objet d'aucune remise)

K KEMMLER®
Präzisionswerkzeuge

Wir fertigen Qualitätsprodukte für höchste Präzision und Wirtschaftlichkeit in der Metallbearbeitung. Wir bieten technische Meisterleistungen mit hervorragendem Preis-Leistungs-Verhältnis: Werkzeugaufnahmen für alle Werkzeugmaschinen nach DIN 2080, DIN 69871, MAS-BT (JIS B 6339), DIN 69893-1 (ISO 12164-1) HSK sowie VDI-Werkzeughalter für Drehmaschinen nach DIN 69880 (ISO 10889). Dazu ein komplettes Peripherie- und Zubehörprogramm rund um die Werkzeugmaschine. Wir arbeiten zuverlässig und schnell, liefern pünktlich, beraten kompetent und unterstützen umfassend. Sie profitieren davon – wie viele zufriedene KEMMLER-Kunden in aller Welt.



KEMMLER® – Precision in perfection

We produce quality products with high-precision and economic efficiency for metal working. We provide a technical masterpiece with an excellent cost-performance ratio: Tool holders for all machine tools with DIN 2080, DIN 69871, MAS-BT (JIS B 6339), DIN 69893-1 (ISO 12164-1) HSK as well as VDI-tool holders for turning machines complying to DIN 69880 (ISO 10889). In addition a complete range of attachments and peripheral items all around machine tools. We work reliable and fast, we deliver in-time, we give competent advice and we support all-embracing. You will take profit – Like many satisfied KEMMLER-Customers all over the world.

KEMMLER® – précision en perfection

Nous fabriquons des produits de qualité d'une précision élevée et en même temps économique pour l'usinage de métal. Nous offrons des solutions d'un haut niveau technique à un excellent rapport qualité-prix : Porte-outils pour toutes les machines-outil selon DIN 2080, DIN 69871, MAS-BT (JIS B 6339), DIN 69893-1 (ISO 12164-1) HSK ainsi que porte-outils VDI pour tours selon DIN 69880 (ISO 10889). Tout cela complété par un programme de périphérie et d'accessoires pour la machine-outil. Nous tenons à nous occuper de nos clients sérieusement et vite, les conseiller et assister d'une manière compétente et fournir ponctuellement. Profitez-en comme tous nos clients contents du monde entier.

Preise gültig bis 31.12. 2018

Netto-Preise pro Stück ab Werk, zzgl. gesetzlicher MwSt.

Prices valid until 31. 12. 2018

Net prices per piece ex works.

Prix valables jusqu'au 31. 12. 2018

Prix nets par pièce départ l'usine.

Druckfehler, Irrtümer und Änderungen vorbehalten.

Dokumentnummer 18-358899-1

Printed in Germany

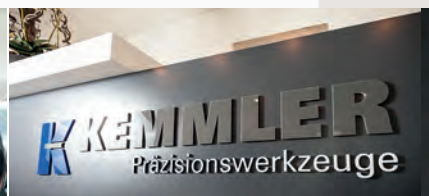



First Class® ist ein eingetragenes Warenzeichen der Kemmler Präzisionswerkzeuge GmbH. Ein Gütesiegel das Präzision, Qualität, Zuverlässigkeit und hervorragenden Service symbolisiert.

First Class® is a licenced trade mark of Kemmler Präzisionswerkzeuge GmbH. A grade standing for precision, quality, reliability and top class service.

First Class® est une marque déposée de Kemmler Präzisionswerkzeuge GmbH. Une marque qui représente la précision, qualité, fiabilité et un service extraordinaire.

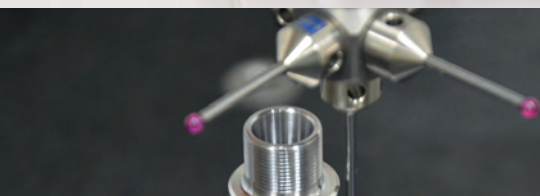
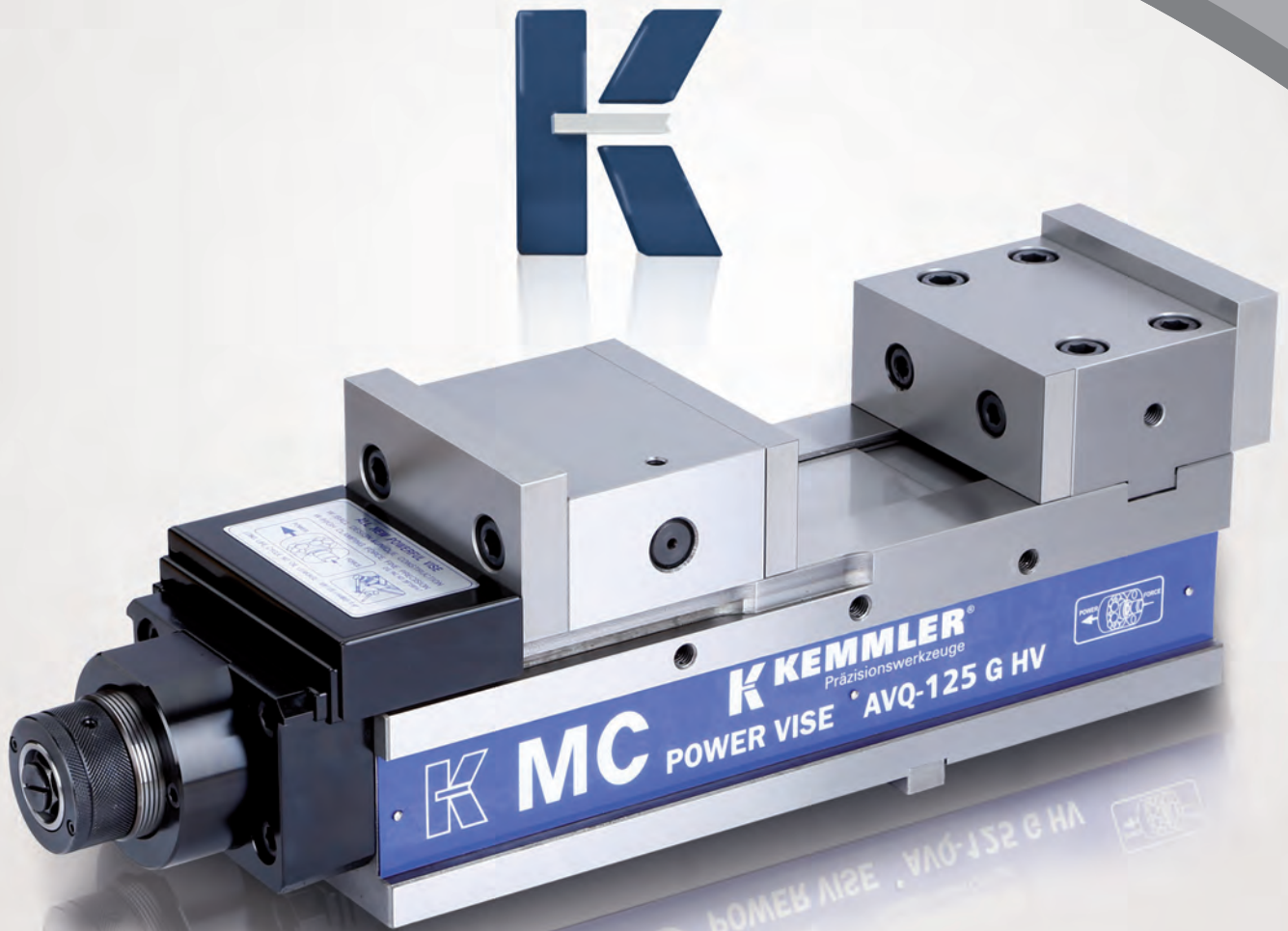



HAAS BMT 65

HAAS BMT 65

HAAS BMT 65

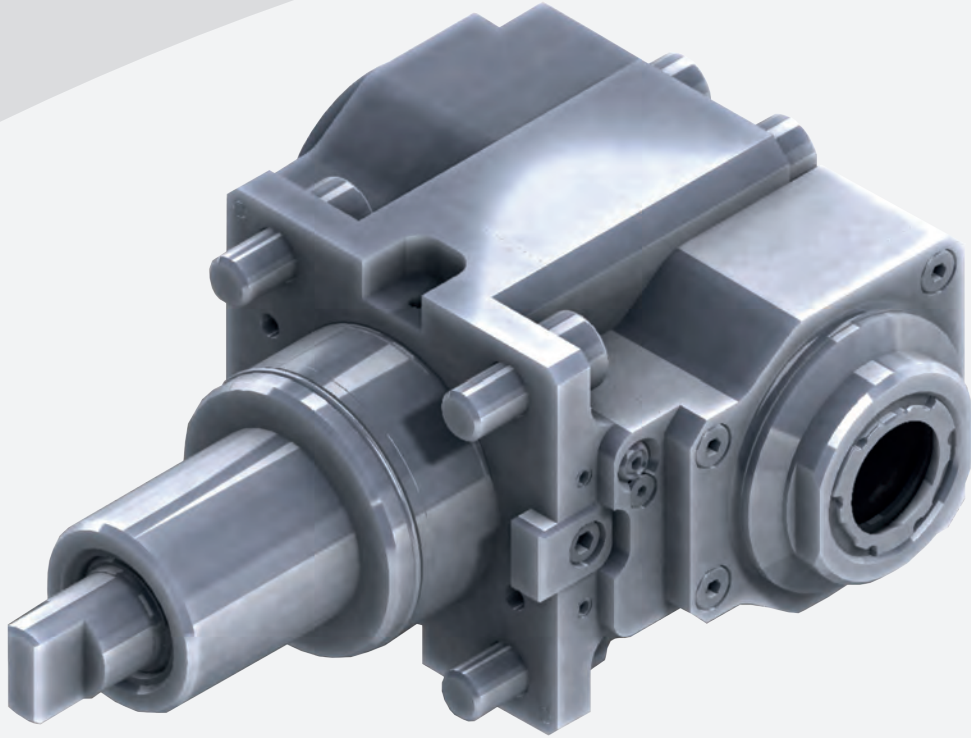

Inhaltsverzeichnis

Index

Sommaire

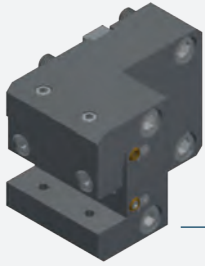

6

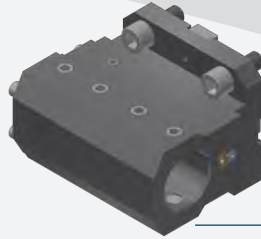

6



7

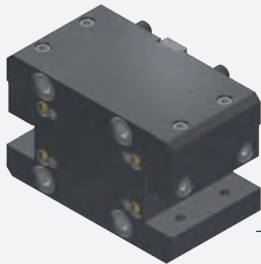

7

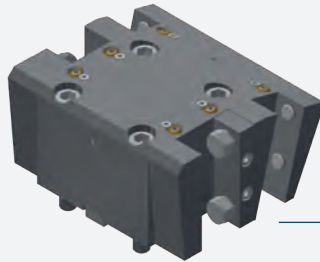

8



8

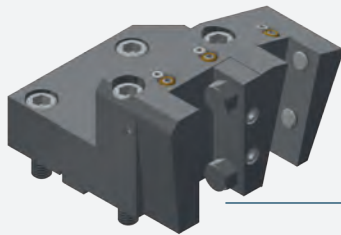

9



9



10

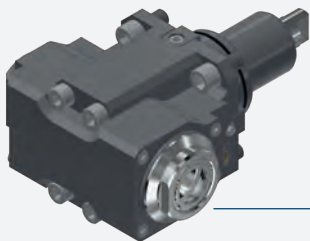

10



11



Werkzeughalter mit Vierkant-Längsaufnahme doppelt

Toolholder with square-longitudinal receptacle doubled

Manche à outils avec porte-outils longitudinal carré double

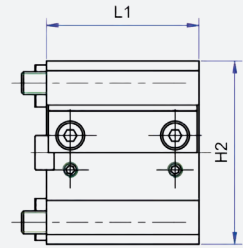
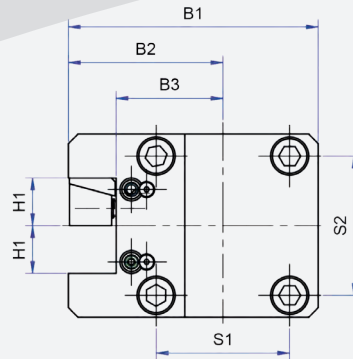
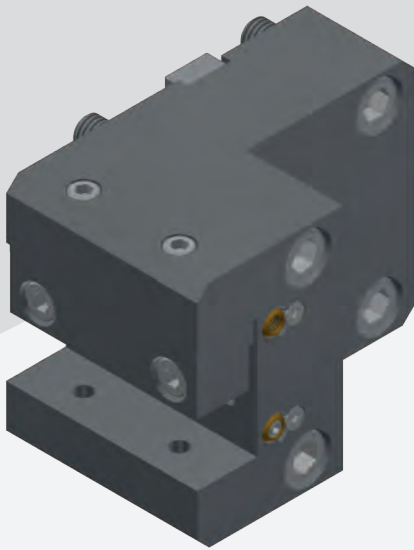

HAAS ST-Line

BMT 65



EC

Bestell-Nr.

Order no.

Référence

AW.102.065.25.755

H1

25

H2

96

B1

131

B2

81

B3

56

L1

80

S1

70

S2

73

Euro

379,00

Zylinderschaftaufnahme

Cylindrical shank receptacle

Support de tige cylindrique

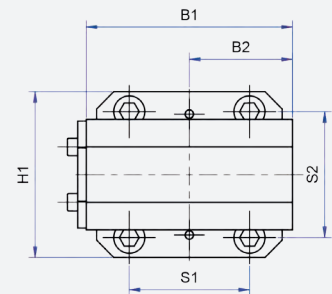
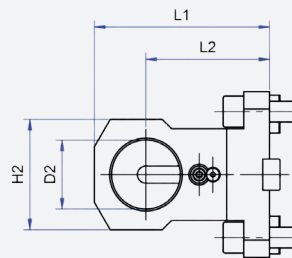
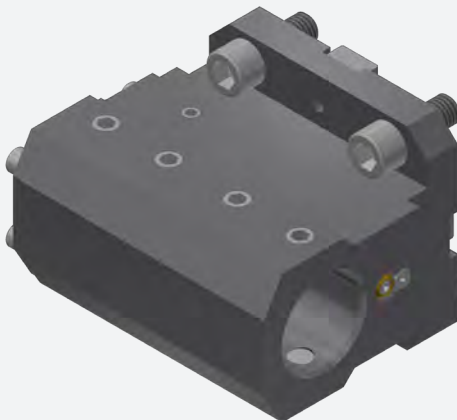

HAAS ST-Line

BMT 65



IC | EC

Bestell-Nr.

Order no.

Référence

AW.107.265.40.750

D2

40

H1

96

H2

64

B1

120

B2

60

L1

102

L2

72

S1

70

S2

73

Euro

322,00

Abstechhalter Vorkopf

Front cut-off toolholder

Porte-outils de tronçonnage frontal

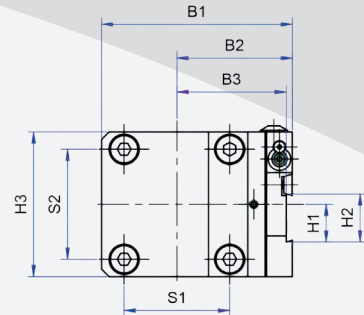
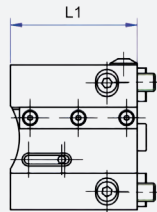
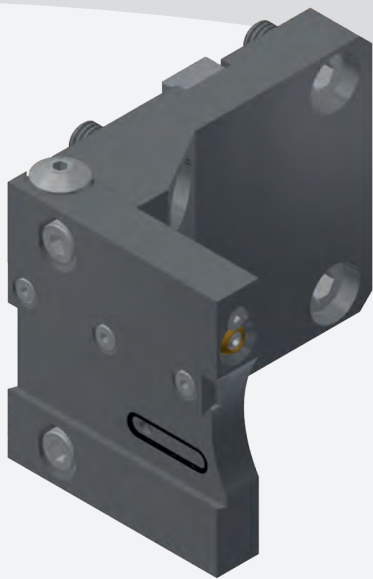

HAAS ST-Line

BMT 65



IC | EC

Bestell-Nr.

Order no.

Référence

AW.105.065.26.753

H1

25

H2

32

H3

96

B1

126,5

B2

76,5

B3

72,5

L1

84

S1

70

S2

73

Euro

715,00

Werkzeughalter mit Vierkant-Mehrfachaufnahme

Toolholder with square-multi-receptacle

Manche à outils avec porte-outils multiple carré

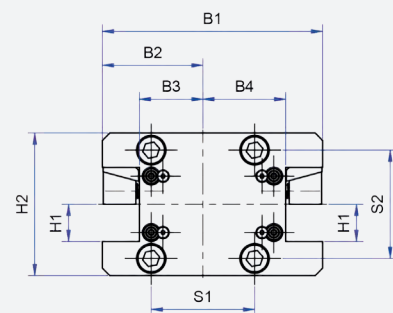
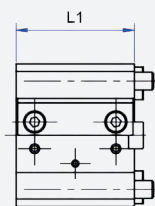
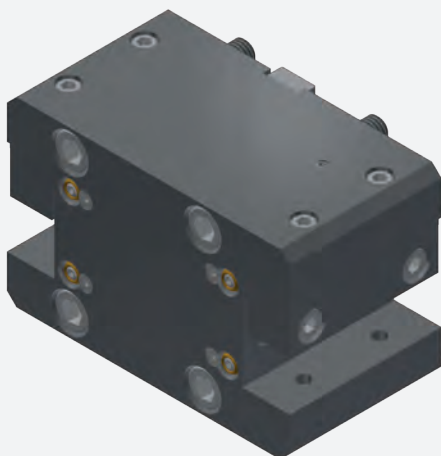

HAAS ST-Line

BMT 65



EC

Bestell-Nr.

Order no.

Référence

AW.103.065.25.755

H1

25

H2

96

B1

149

B2

68

B3

43

B4

56

L1

80

S1

70

S2

73

Euro

472,00



Werkzeughalter mit Vierkant-Mehrfachaufnahme

Toolholder with square-multi-receptacle

Manche à outils avec porte-outils multiple carré

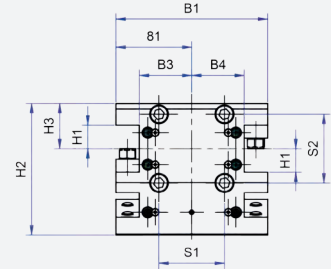
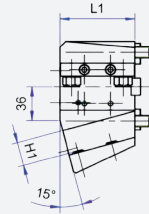
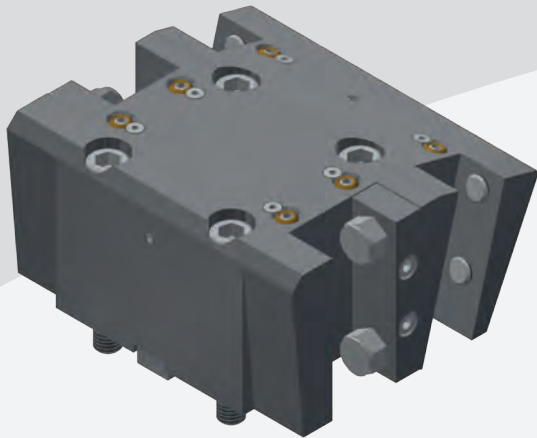

HAAS ST-Line

BMT 65



Bestell-Nr.

Order no.

Référence

AW.103.065.25.756

H1

25

H2

139,873

H3

48

B1

162

B2

81

B3

56

B4

56

L1

80

S1

70

S2

73

Euro

786,00

Zylinderschaftaufnahme

Cylindrical shank receptacle

Support de tige cylindrique

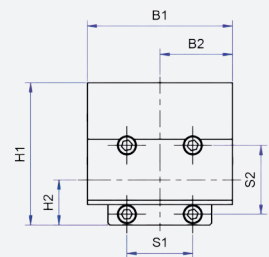
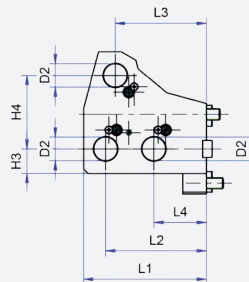

HAAS ST-Line

BMT 65



Bestell-Nr.

Order no.

Référence

AW.107.265.25.756

D2

25

H1

151

H2

48

H3

26

H4

77,82

B1

154

B2

77

L1

130,5

L2

107

L3

96,755

L4

56

S1

70

S2

73

Euro

786,00

Werkzeughalter mit Vierkant-Mehrfachaufnahme

Toolholder with square-multi-receptacle

Manche à outils avec porte-outils multiple carré

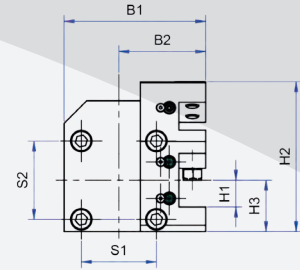
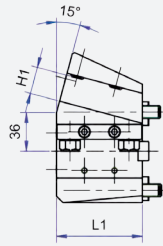
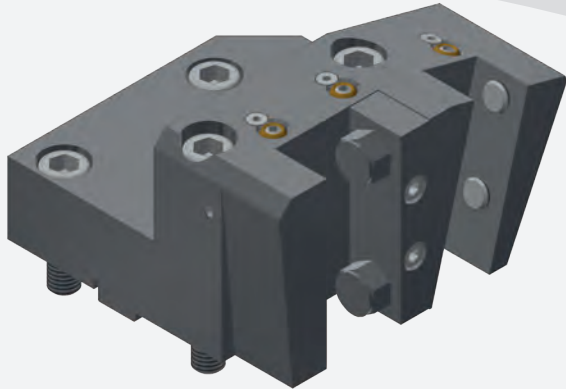

HAAS ST-Line

BMT 65



EC

Bestell-Nr.

Order no.

Référence

AW.103.065.25.753

H1

H2

H3

B1

B2

L1

S1

S2

Euro

25

139,873

48

132

81

80

70

73

643,00

Zylinderschaftaufnahme

Cylindrical shank receptacle

Support de tige cylindrique

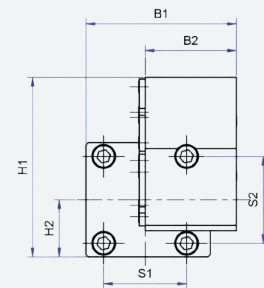
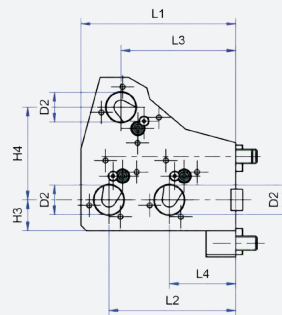
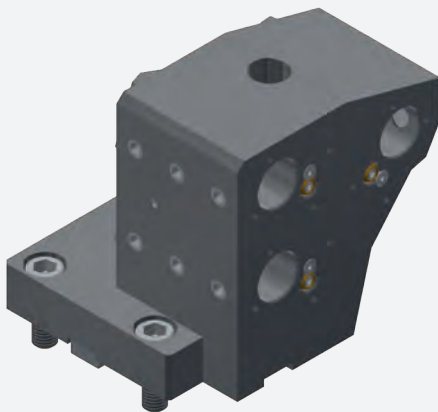

HAAS ST-Line

BMT 65



IC | EC

Bestell-Nr.

Order no.

Référence

AW.107.265.25.753

D2

H1

H2

H3

H4

B1

B2

L1

L2

L3

L4

S1

S2

Euro

25

151

48

26

77,82

127

77

130,5

107

96,755

56

70

73

786,00



Axial Bohr- und Fräskopf

Axial drilling head

Tête d'alésage et de fraisage axiale

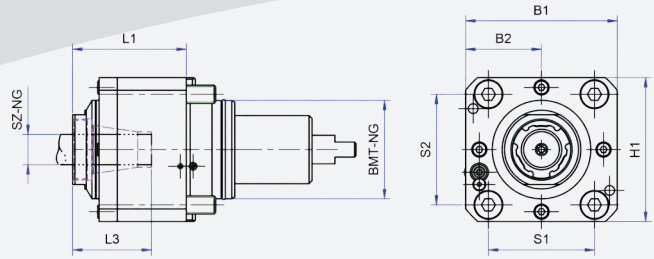

HAAS ST-Line	BMT 65	EC	ER 32	1:1
--------------	--------	----	-------	-----

Bestell-Nr. Order no. Référence	B1	B2	H1	L1	L3	S1	S2	n max. min-1	T max. Nm	Euro
AW.221.065.20.751	100	50	95	75	52	70	73	6000	60	743,00

Radial Bohr- und Fräskopf

Radial drilling and milling head

Tête d'alésage et de fraisage radiale

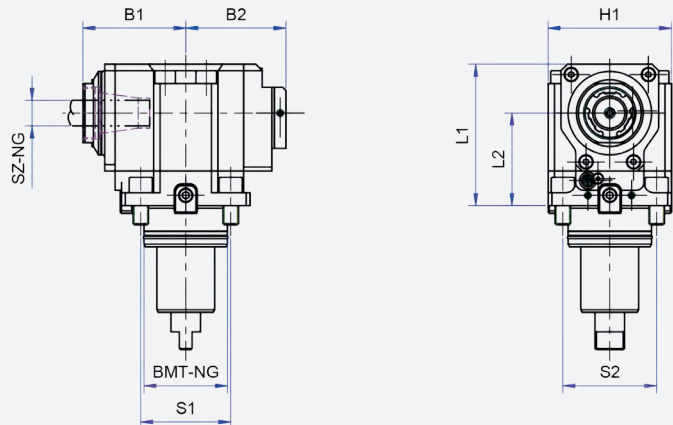
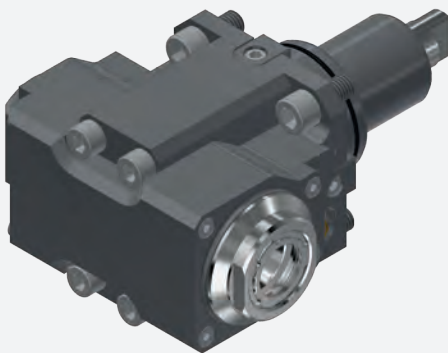

HAAS ST-Line	BMT 65	EC	ER 32	1:1
--------------	--------	----	-------	-----

Bestell-Nr. Order no. Référence	B1	B2	H1	L1	L2	S1	S2	n max. min-1	T max. Nm	Euro
AW.221.265.20.751	80	67	96	110	72	70	73	6000	54	1.286,00

Spannfutter mit Zylinderschaft mit Spannfläche für Spannzangen DIN 6499 (ISO 15488) System ER

Collet chucks with straight shank with with clamping surface for collets DIN 6499 (ISO 15488) ER-system

Mandrins à pinces à queue cylindrique avec surface de serrage pour pinces DIN 6499 (ISO 15488) système ER



Verwendung:
Zur Aufnahme von Werkzeugen mit Zylinderschaft in Spannzangen.

Application:
For mounting straight-shank tools in collets.

Application:
Pour le serrage d'outils avec queue cylindrique dans des pinces de serrage.

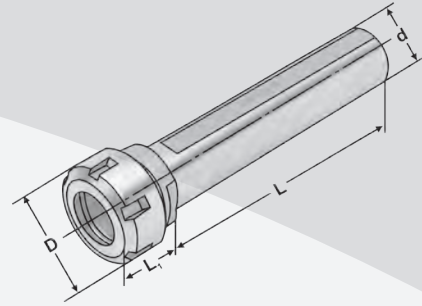

Form AD	$\nearrow \leq 0,003$	CAD
---------	-----------------------	-----

Bestell-Nr. Order no. Référence	d _{H6}	Spannbereich Capacity Capacité	L	L ₁	D	Euro
120.02.04.20.1	40	2 – 20 (ER 32)	120	41	50	68,50

Zeta Spannschlüssel ER32

Zeta wrenche ER32

Zeta clés de serrage ER32



Bestell-Nr. Order no. Référence	Spannbereich Capacity Capacité	Euro
AW.SE32	2 – 20 (ER 32)	78,00

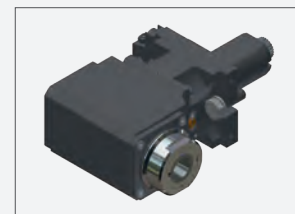

Mehr Produkte und Informationen finden Sie in unserem Hauptkatalog.
Please check our catalogue for more products and detailed informations.
Vous trouvez plus de produits et d'informations dans notre catalogue général.



facebook.com/kemmler



www.kemmler-tools.de



Mehr Produkte und Informationen finden Sie in unserem Hauptkatalog.

Please check our catalogue for more products and detailed informations.

Vous trouvez plus de produits et d'informations dans notre catalogue général.

K KEMMLER®
Präzisionswerkzeuge

Kemmler Präzisionswerkzeuge GmbH

Lange Str. 101
72116 Mössingen
Deutschland

Telefon: +49 7473 92408-0
Telefax: +49 7473 92408-20

info@kemmler-tools.de
www.kemmler-tools.de
facebook.com/kemmler



panas

PANAS Tools s.r.o., Hradište 371, 95854 Tel. +421 (0)38 7496764-5,
panas@panas.sk, info@panas.sk , www.panas.sk