

Specification: ISO 228

Použitie: rúrkové závitky na všeobecné použitie, kde sa na závitoch nevyžadujú tlakotesné spoje.

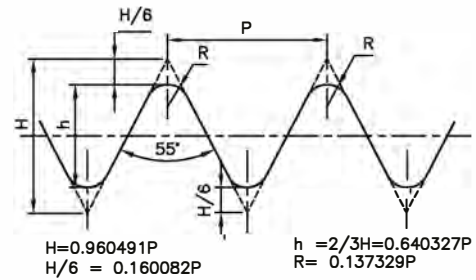

Na sklade Na objednávku

The Sizes not covered in catalogue are in our manufacturing program. PRICES ON REQUEST

Size		Catalogue Code	RH			LH		
Diameter	TPI		Go & Nogo Plug RH	Go Plug RH	Nogo Plug RH	Go & Nogo Plug LH	Go Plug LH	Nogo Plug LH
			00 DR	00 GR	00 NR	00 DL	00 GL	00 NL
G 1/8	28	P GG 00108 028	✓	NA	NA	✓	NA	NA
G 1/4	19	P GG 00104 019	✓	NA	NA	✓	NA	NA
G 3/8	19	P GG 00308 019	✓	NA	NA	✓	NA	NA
G 1/2	14	P GG 00102 014	✓	NA	NA	✓	NA	NA
G 5/8	14	P GG 00508 014	✓	NA	NA	✓	NA	NA
G 3/4	14	P GG 00304 014	✓	NA	NA	✓	NA	NA
G 7/8	14	P GG 00708 014	✓	NA	NA	✓	NA	NA
G 1	11	P GG 00100 011	✓	NA	NA	✓	NA	NA
G 1-1/8	11	P GG 00118 011	✓	NA	NA	✓	NA	NA
G1-1/4	11	P GG 00114 011	✓	NA	NA	✓	NA	NA
G 1-3/8	11	P GG 00138 011	✓	NA	NA	✓	NA	NA
G 1-1/2	11	P GG 00112 011	✓	NA	NA	✓	NA	NA
G 1-3/4	11	P GG 00134 011	✓	NA	NA	✓	NA	NA
G 2	11	P GG 00200 011	✓	NA	NA	✓	NA	NA
G 2-1/4	11	P GG 00214 011	NA	✓	✓	NA	○	○
G 2-1/2	11	P GG 00212 011	NA	✓	✓	NA	○	○
G 2-3/4	11	P GG 00234 011	NA	✓	✓	NA	○	○
G 3	11	P GG 00300 011	NA	✓	✓	NA	○	○
G 3-1/2	11	P GG 00312 011	NA	✓	✓	NA	○	○
G 4	11	P GG 00400 011	NA	✓	✓	NA	○	○
G 5	11	P GG 00500 011	NA	○	○	NA	○	○
G 6	11	P GG 00600 011	NA	○	○	NA	○	○

NA - Nedostupné

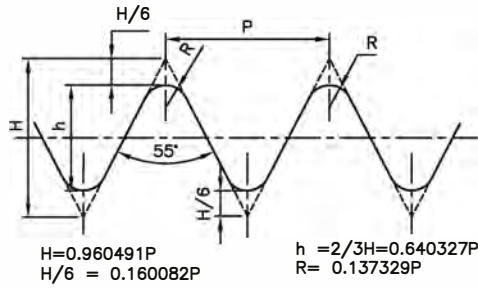

✓ Na sklade

○ Na objednávku

The Sizes not covered in catalogue are in our manufacturing program. PRICES ON REQUEST

Size		Catalogue Code	Right Hand (RH)				Left Hand (LH)			
Diameter	TPI		Go Ring Class-A RH	Nogo Ring Class-A RH	Go Ring Class-B RH	Nogo Ring Class-B RH	Go Ring Class-A LH	Nogo Ring Class-A LH	Go Ring Class-B LH	Nogo Ring Class-B LH
			A0 GR	A0 NR	B0 GR	B0 NR	A0 GL	A0 NL	B0 GL	B0 NL
G 1/8	28	R GG 00108 028	✓	✓	✓	✓	✓	✓	○	○
G 1/4	19	R GG 00104 019	✓	✓	✓	✓	✓	✓	○	○
G 3/8	19	R GG 00308 019	✓	✓	✓	✓	✓	✓	○	○
G 1/2	14	R GG 00102 014	✓	✓	✓	✓	✓	✓	○	○
G 5/8	14	R GG 00508 014	✓	✓	✓	✓	✓	✓	○	○
G 3/4	14	R GG 00304 014	✓	✓	✓	✓	✓	✓	○	○
G 7/8	14	R GG 00708 014	✓	✓	✓	✓	○	○	○	○
G 1	11	R GG 00100 011	✓	✓	✓	✓	✓	✓	○	○
G 1-1/8	11	R GG 00118 011	✓	✓	✓	✓	○	○	○	○
G1-1/4	11	R GG 00114 011	✓	✓	✓	✓	✓	✓	○	○
G 1-3/8	11	R GG 00138 011	✓	✓	✓	✓	○	○	○	○
G 1-1/2	11	R GG 00112 011	✓	✓	✓	✓	✓	✓	○	○
G 1-3/4	11	R GG 00134 011	✓	✓	✓	✓	✓	✓	○	○
G 2	11	R GG 00200 011	✓	✓	✓	✓	✓	✓	○	○
G 2-1/4	11	R GG 00214 011	✓	✓	✓	✓	✓	✓	○	○
G 2-1/2	11	R GG 00212 011	✓	✓	✓	✓	✓	✓	○	○
G 2-3/4	11	R GG 00234 011	✓	✓	✓	✓	✓	✓	○	○
G 3	11	R GG 00300 011	✓	✓	✓	✓	✓	✓	○	○
G 3-1/2	11	R GG 00312 011	○	○	○	○	○	○	○	○
G 4	11	R GG 00400 011	○	○	○	○	○	○	○	○
G 5	11	R GG 00500 011	○	○	○	○	○	○	○	○
G 6	11	R GG 00600 011	○	○	○	○	○	○	○	○



Specification: DIN 40430 / DIN 40431

Application: Checking threads of Conduit pipes used for electrical piping for wiring.

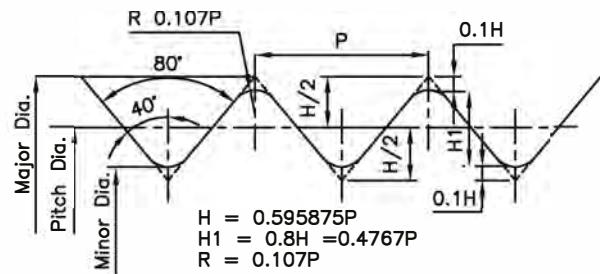

✓ Na sklade

○ Na objednávku

Size		Catalogue Code	Go & Nogo Plug RH	
	TPI			
			00 DR	
Pg 7	20	P PG 00007 020	✓	
Pg 9	18	P PG 00009 018	✓	
Pg 11	18	P PG 00011 018	✓	
Pg 13.5	18	P PG 00135 018	✓	
Pg 16	18	P PG 00016 018	✓	
Pg 21	16	P PG 00021 016	✓	
Pg 29	16	P PG 00029 016	✓	
Pg 36	16	P PG 00036 016	✓	
Pg 42	16	P PG 00042 016	✓	
Pg 48	16	P PG 00048 016	✓	



Go & Nogo Plug RH

00 DR



Nogo je čistý bez závitov.

Pg KRÚŽOK

✓ Na sklade

○ Na objednávku

Size		Catalogue Code	Go Ring RH		Nogo Ring Plain / Cylindrical	
Diameter	TPI					
			00 GR		00 NO	
Pg 7	20	R PG 00007 020	✓		✓	
Pg 9	18	R PG 00009 018	✓		✓	
Pg 11	18	R PG 00011 018	✓		✓	
Pg 13.5	18	R PG 00135 018	✓		✓	
Pg 16	18	R PG 00016 018	✓		✓	
Pg 21	16	R PG 00021 016	✓		✓	
Pg 29	16	R PG 00029 016	✓		✓	
Pg 36	16	R PG 00036 016	✓		✓	
Pg 42	16	R PG 00042 016	✓		✓	
Pg 48	16	R PG 00048 016	✓		✓	



Go Ring RH

Nogo Ring Plain / Cylindrical

00 GR

00 NO



Specification: DIN 2999

Použitie: potrubné závitky, kde sa vyžadujú tlakotesné spoje na závitoch. kužel 1:16 na priemere

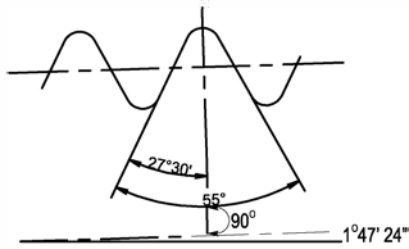

Taper 1 in 16 on diameter
Taper Thread Plug

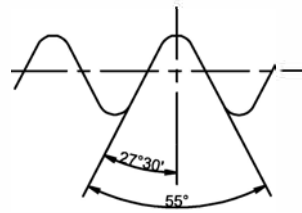

Parallel Thread Ring

TAPER PLUG

✓ Na sklade ○ Na objednávku

Size	TPI	Catalogue Code		
			Taper Thread Plug	CP to check Ring
			00 TR	00 CR
R1/8	28	P RD 00108 028	✓	○
R1/4	19	P RD 00104 019	✓	○
R3/8	19	P RD 00308 019	✓	○
R1/2	14	P RD 00102 014	✓	○
R3/4	14	P RD 00304 014	✓	○
R1	11	P RD 00100 011	✓	○
R1-1/4	11	P RD 00114 011	✓	○
R 1-1/2	11	P RD 00112 011	✓	○
R 2	11	P RD 00200 011	✓	○
R 2-1/2	11	P RD 00212 011	✓	○
R 3	11	P RD 00300 011	✓	○
R 4	11	P RD 00400 011	✓	○



panas

PARALLEL RING

✓ Na sklade ○ Na objednávku



Size	TPI	Catalogue Code	
			Parallel Thread Ring
			00 PR
R1/8	28	R RD 00108 028	○
R1/4	19	R RD 00104 019	✓
R3/8	19	R RD 00308 019	✓
R1/2	14	R RD 00102 014	✓
R3/4	14	R RD 00304 014	✓
R1	11	R RD 00100 011	✓
R1-1/4	11	R RD 00114 011	✓
R 1-1/2	11	R RD 00112 011	✓
R 2	11	R RD 00200 011	✓
R 2-1/2	11	R RD 00212 011	✓
R 3	11	R RD 00300 011	✓
R 4	11	R RD 00400 011	○

Specification: **BS EN 10226 OR / ISO 712**

Použitie: potrubné závit, kde sa vyžadujú tlakotesné spoje na závitoch. kužela 1:16 na priemere

Trň

na kontrolu vnútorných valcových závitov (Rp) a kuželových závitov (Rc).

Na sklade Na objednávku

Size		Catalogue Code	Taper Full Form Thread Plug	Taper Full Form Thread Plug with relief	Taper Modified Form Check Plug for Ring
Diameter	TPI		No.1	No. 2	No. 5
R1/8	28	PRC 00108 028	✓	○	○
R1/4	19	PRC 00104 019	✓	○	○
R3/8	19	PRC 00308 019	✓	○	○
R1/2	14	PRC 00102 014	✓	○	○
R3/4	14	PRC 00304 014	✓	○	○
R1	11	PRC 00100 011	✓	○	○
R1-1/4	11	PRC 00114 011	✓	○	○
R 1-1/2	11	PRC 00112 011	✓	○	○
R 2	11	PRC 00200 011	✓	○	○
R 2-1/2	11	PRC 00212 011	✓	○	○
R 3	11	PRC 00300 011	✓	○	○
R 4	11	PRC 00400 011	✓	○	○

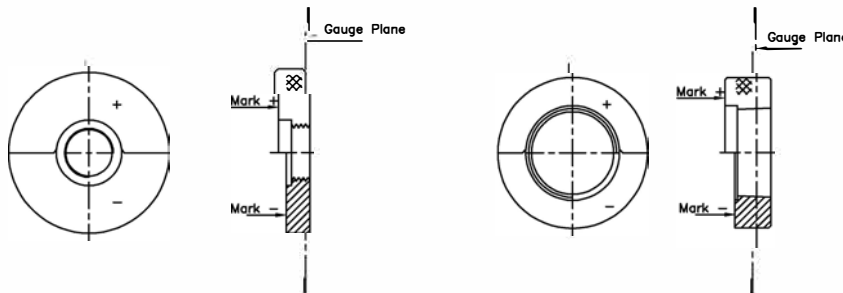
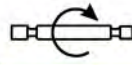

Parallel Full form Thread Ring Gauge. Gauge No.3

Taper Plain Ring Gauge (without threads) Gauge No.4



KRÚŽOK

Na kontrolu vonkajšieho kuželového závit(R)

Na sklade Na objednávku

Size		Catalogue Code	Parallel Full Form Thread Ring	Taper Plain Ring	Parallel Modified Thread Form Ring
Diameter	TPI		No. 3	No. 4	No. 6
R1/8	28	R RC 00108 028	✓	○	○
R1/4	19	R RC 00104 019	✓	✓	○
R3/8	19	R RC 00308 019	✓	✓	○
R1/2	14	R RC 00102 014	✓	✓	○
R3/4	14	R RC 00304 014	✓	✓	○
R1	11	R RC 00100 011	✓	✓	○
R1-1/4	11	R RC 00114 011	✓	✓	○
R 1-1/2	11	R RC 00112 011	✓	✓	○
R 2	11	R RC 00200 011	✓	✓	○
R 2-1/2	11	R RC 00212 011	✓	○	○
R 3	11	R RC 00300 011	✓	○	○
R 4	11	R RC 00400 011	✓	○	○



Specification: **Basic ASME B 1.20.1**
Step Limit : American Handbook H-28

Použitie: NPT[™] závitů sa používajú vo všeobecných aplikáciách montáže rúr, kde sa vytvára tlakotesný spoj rúr, a to tak, že sú rúry pevne utiahnuté pomocou tesniacej hmoty.
 Kužel 1:16 na priemere

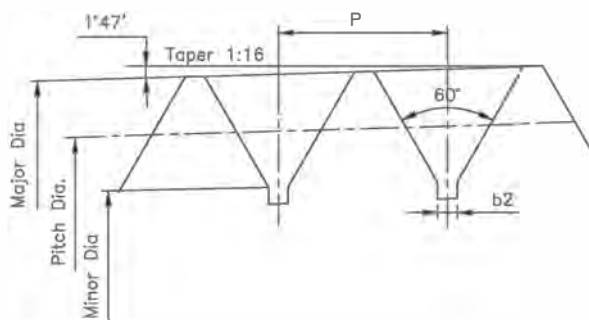

Our manufacturing program includes NPT L3 Plugs & NPT L2 Rings. PRICES ON REQUEST

Na sklade

Na objednávku

Size			Thread Plug	
Diameter	TPI	Catalogue Code	L1 Basic	L1 Step Limit
1/16	27	P NT 00116 027	<input checked="" type="checkbox"/>	<input checked="" type="checkbox"/>
1/8	27	P NT 00108 027	<input checked="" type="checkbox"/>	<input checked="" type="checkbox"/>
1/4	18	P NT 00104 018	<input checked="" type="checkbox"/>	<input checked="" type="checkbox"/>
3/8	18	P NT 00308 018	<input checked="" type="checkbox"/>	<input checked="" type="checkbox"/>
1/2	14	P NT 00102 014	<input checked="" type="checkbox"/>	<input checked="" type="checkbox"/>
3/4	14	P NT 00304 014	<input checked="" type="checkbox"/>	<input checked="" type="checkbox"/>
1	11.5	P NT 00100 115	<input checked="" type="checkbox"/>	<input checked="" type="checkbox"/>
1.1/4	11.5	P NT 00114 115	<input checked="" type="checkbox"/>	<input checked="" type="checkbox"/>
1.1/2	11.5	P NT 00112 115	<input checked="" type="checkbox"/>	<input checked="" type="checkbox"/>
2	11.5	P NT 00200 115	<input checked="" type="checkbox"/>	<input checked="" type="checkbox"/>
2.1/2	8	P NT 00212 008	<input checked="" type="checkbox"/>	<input checked="" type="checkbox"/>
3	8	P NT 00300 008	<input checked="" type="checkbox"/>	<input checked="" type="checkbox"/>
3.1/2	8	P NT 00312 008	<input type="checkbox"/>	<input type="checkbox"/>
4	8	P NT 00400 008	<input checked="" type="checkbox"/>	<input checked="" type="checkbox"/>
4.1/2	8	P NT 00412 008	<input type="checkbox"/>	<input type="checkbox"/>
5	8	P NT 00500 008	<input type="checkbox"/>	<input type="checkbox"/>
6	8	P NT 00600 008	<input type="checkbox"/>	<input type="checkbox"/>
8	8	P NT 00800 008	<input type="checkbox"/>	<input type="checkbox"/>
10	8	P NT 01000 008	<input type="checkbox"/>	<input type="checkbox"/>
12	8	P NT 01200 008	<input type="checkbox"/>	<input type="checkbox"/>

Size			Thread Ring	
Diameter	TPI	Catalogue Code	L1 Basic	L1 Step Limit
1/16	27	R NT 00116 027	<input checked="" type="checkbox"/>	<input checked="" type="checkbox"/>
1/8	27	R NT 00108 027	<input checked="" type="checkbox"/>	<input checked="" type="checkbox"/>
1/4	18	R NT 00104 018	<input checked="" type="checkbox"/>	<input checked="" type="checkbox"/>
3/8	18	R NT 00308 018	<input checked="" type="checkbox"/>	<input checked="" type="checkbox"/>
1/2	14	R NT 00102 014	<input checked="" type="checkbox"/>	<input checked="" type="checkbox"/>
3/4	14	R NT 00304 014	<input checked="" type="checkbox"/>	<input checked="" type="checkbox"/>
1	11.5	R NT 00100 115	<input checked="" type="checkbox"/>	<input checked="" type="checkbox"/>
1.1/4	11.5	R NT 00114 115	<input checked="" type="checkbox"/>	<input checked="" type="checkbox"/>
1.1/2	11.5	R NT 00112 115	<input checked="" type="checkbox"/>	<input checked="" type="checkbox"/>
2	11.5	R NT 00200 115	<input checked="" type="checkbox"/>	<input checked="" type="checkbox"/>
2.1/2	8	R NT 00212 008	<input checked="" type="checkbox"/>	<input checked="" type="checkbox"/>
3	8	R NT 00300 008	<input checked="" type="checkbox"/>	<input checked="" type="checkbox"/>
3.1/2	8	R NT 00312 008	<input type="checkbox"/>	<input type="checkbox"/>
4	8	R NT 00400 008	<input checked="" type="checkbox"/>	<input checked="" type="checkbox"/>
4.1/2	8	R NT 00412 008	<input type="checkbox"/>	<input type="checkbox"/>
5	8	R NT 00500 008	<input type="checkbox"/>	<input type="checkbox"/>
6	8	R NT 00600 008	<input type="checkbox"/>	<input type="checkbox"/>
8	8	R NT 00800 008	<input type="checkbox"/>	<input type="checkbox"/>
10	8	R NT 01000 008	<input type="checkbox"/>	<input type="checkbox"/>

• ANPT Kalibre sú v našom výrobnom programe. CENY NA VYŽIADANIE.

Specification: **ASME B 1.20.6**
ASME B 1.20.5

Použitie: Závitý NPTF môžu poskytnúť tlakové tesnenie na závitoch bez použitia tesniacej hmoty (typ suchého tesnenia) PTF sú krátke meradlá (menšia hrúbka), ktoré sa používajú na aplikáciu podobne ako NPTF

Kužel 1:16 na priemere



TAPER TRN

Na sklade Na objednávku

Size			Catalogue Code	Thread Plug		Thread Plug		6 Step Crest Truncation Plug
Diameter	TPI	L1 Basic		L1 Step Limit	L3 Basic	L3 Step Limit		
1/16	27	P TF 00116 027	<input checked="" type="checkbox"/>	<input checked="" type="checkbox"/>	<input type="checkbox"/>	<input type="checkbox"/>	<input type="checkbox"/>	
1/8	27	P TF 00108 027	<input checked="" type="checkbox"/>	<input checked="" type="checkbox"/>	<input type="checkbox"/>	<input type="checkbox"/>	<input type="checkbox"/>	
1/4	18	P TF 00104 018	<input checked="" type="checkbox"/>	<input checked="" type="checkbox"/>	<input type="checkbox"/>	<input type="checkbox"/>	<input type="checkbox"/>	
3/8	18	P TF 00308 018	<input checked="" type="checkbox"/>	<input checked="" type="checkbox"/>	<input type="checkbox"/>	<input type="checkbox"/>	<input type="checkbox"/>	
1/2	14	P TF 00102 014	<input checked="" type="checkbox"/>	<input checked="" type="checkbox"/>	<input type="checkbox"/>	<input type="checkbox"/>	<input type="checkbox"/>	
3/4	14	P TF 00304 014	<input checked="" type="checkbox"/>	<input checked="" type="checkbox"/>	<input type="checkbox"/>	<input type="checkbox"/>	<input type="checkbox"/>	
1	11.5	P TF 00100 115	<input checked="" type="checkbox"/>	<input checked="" type="checkbox"/>	<input type="checkbox"/>	<input type="checkbox"/>	<input type="checkbox"/>	
1.1/4	11.5	P TF 00114 115	<input checked="" type="checkbox"/>	<input checked="" type="checkbox"/>	<input type="checkbox"/>	<input type="checkbox"/>	<input type="checkbox"/>	
1.1/2	11.5	P TF 00112 115	<input checked="" type="checkbox"/>	<input checked="" type="checkbox"/>	<input type="checkbox"/>	<input type="checkbox"/>	<input type="checkbox"/>	
2	11.5	P TF 00200 115	<input checked="" type="checkbox"/>	<input checked="" type="checkbox"/>	<input type="checkbox"/>	<input type="checkbox"/>	<input type="checkbox"/>	
2.1/2	8	P TF 00212 008	<input checked="" type="checkbox"/>	<input checked="" type="checkbox"/>	<input type="checkbox"/>	<input type="checkbox"/>	<input type="checkbox"/>	
3	8	P TF 00300 008	<input checked="" type="checkbox"/>	<input checked="" type="checkbox"/>	<input type="checkbox"/>	<input type="checkbox"/>	<input type="checkbox"/>	

TAPER KRÚŽOK

Na sklade Na objednávku

Size			Catalogue Code	Thread Ring		Thread Ring		6 Step Crest Truncation Ring
Diameter	TPI	L1 Basic		L1 Step Limit	L2 Basic	L2 Step Limit		
1/16	27	R TF 00116 027	<input checked="" type="checkbox"/>	<input checked="" type="checkbox"/>	<input type="checkbox"/>	<input type="checkbox"/>	<input type="checkbox"/>	
1/8	27	R TF 00108 027	<input checked="" type="checkbox"/>	<input checked="" type="checkbox"/>	<input type="checkbox"/>	<input type="checkbox"/>	<input type="checkbox"/>	
1/4	18	R TF 00104 018	<input checked="" type="checkbox"/>	<input checked="" type="checkbox"/>	<input type="checkbox"/>	<input type="checkbox"/>	<input type="checkbox"/>	
3/8	18	R TF 00308 018	<input checked="" type="checkbox"/>	<input checked="" type="checkbox"/>	<input type="checkbox"/>	<input type="checkbox"/>	<input type="checkbox"/>	
1/2	14	R TF 00102 014	<input checked="" type="checkbox"/>	<input checked="" type="checkbox"/>	<input type="checkbox"/>	<input type="checkbox"/>	<input type="checkbox"/>	
3/4	14	R TF 00304 014	<input checked="" type="checkbox"/>	<input checked="" type="checkbox"/>	<input type="checkbox"/>	<input type="checkbox"/>	<input type="checkbox"/>	
1	11.5	R TF 00100 115	<input checked="" type="checkbox"/>	<input checked="" type="checkbox"/>	<input type="checkbox"/>	<input type="checkbox"/>	<input type="checkbox"/>	
1.1/4	11.5	R TF 00114 115	<input checked="" type="checkbox"/>	<input checked="" type="checkbox"/>	<input type="checkbox"/>	<input type="checkbox"/>	<input type="checkbox"/>	
1.1/2	11.5	R TF 00112 115	<input checked="" type="checkbox"/>	<input checked="" type="checkbox"/>	<input type="checkbox"/>	<input type="checkbox"/>	<input type="checkbox"/>	
2	11.5	R TF 00200 115	<input checked="" type="checkbox"/>	<input checked="" type="checkbox"/>	<input type="checkbox"/>	<input type="checkbox"/>	<input type="checkbox"/>	
2.1/2	8	R TF 00212 008	<input checked="" type="checkbox"/>	<input checked="" type="checkbox"/>	<input type="checkbox"/>	<input type="checkbox"/>	<input type="checkbox"/>	
3	8	R TF 00300 008	<input checked="" type="checkbox"/>	<input checked="" type="checkbox"/>	<input type="checkbox"/>	<input type="checkbox"/>	<input type="checkbox"/>	



Crest Truncation 6 steps

Specification: **CGAV -1 / American Handbook H-28**
Aplikácia: Používa sa na kontrolu driekov ventilov plynovej flaše a závitov hrdla flaše. Kužel s priemerom 1:16

TAPER TRN
 Na sklade Na objednávku

Size		Catalogue Code	Taper Thread Plug Taper Thread Plug CP to check L1 & L8 Rings Taper Plain Plug Taper Plain Plug				
Diameter	TPI		L1	L9	CP to check L1 & L8 Rings	C1	C2
			L1 0R	L9 0R	CP 0R	C1 00	C2 00
1/8	27	P NG 00108 027	<input type="checkbox"/>	<input type="checkbox"/>	<input type="checkbox"/>	<input type="checkbox"/>	<input type="checkbox"/>
1/4	18	P NG 00104 018	<input type="checkbox"/>	<input type="checkbox"/>	<input type="checkbox"/>	<input type="checkbox"/>	<input type="checkbox"/>
3/8	18	P NG 00308 018	<input type="checkbox"/>	<input type="checkbox"/>	<input type="checkbox"/>	<input type="checkbox"/>	<input type="checkbox"/>
1/2	14	P NG 00102 014	<input type="checkbox"/>	<input type="checkbox"/>	<input type="checkbox"/>	<input type="checkbox"/>	<input type="checkbox"/>
3/4	14	P NG 00304 014	<input checked="" type="checkbox"/>	<input checked="" type="checkbox"/>	<input checked="" type="checkbox"/>	<input checked="" type="checkbox"/>	<input checked="" type="checkbox"/>
1	11.5	P NG 00100 115	<input type="checkbox"/>	<input type="checkbox"/>	<input type="checkbox"/>	<input type="checkbox"/>	<input type="checkbox"/>
1-1/2	11.5	P NG 00112 115	<input type="checkbox"/>	<input type="checkbox"/>	<input type="checkbox"/>	<input type="checkbox"/>	<input type="checkbox"/>

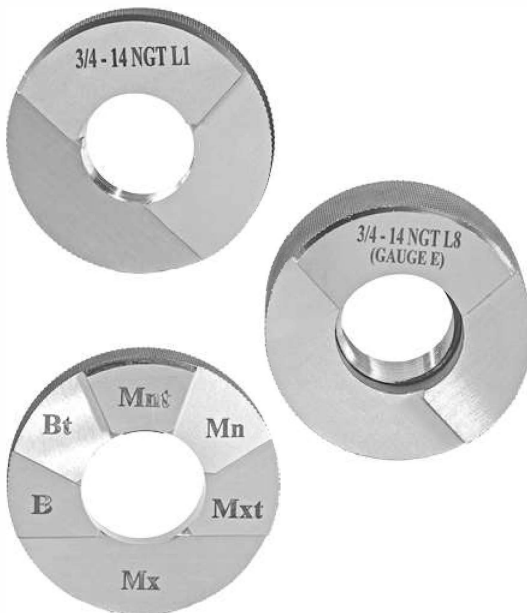
TAPER KRÚŽOK
 Na sklade Na objednávku

Size		Catalogue Code	Taper Thread Ring Taper Thread Ring Crest Truncation Ring (6 Steps)		
Diameter	TPI		L1	L8	Crest Truncation Ring (6 Steps)
			L1 0R	L8 0R	CR 06
1/8	27	R NG 00108 027	<input type="checkbox"/>	<input type="checkbox"/>	<input type="checkbox"/>
1/4	18	R NG 00104 018	<input type="checkbox"/>	<input type="checkbox"/>	<input type="checkbox"/>
3/8	18	R NG 00308 018	<input type="checkbox"/>	<input type="checkbox"/>	<input type="checkbox"/>
1/2	14	R NG 00102 014	<input type="checkbox"/>	<input type="checkbox"/>	<input type="checkbox"/>
3/4	14	R NG 00304 014	<input checked="" type="checkbox"/>	<input checked="" type="checkbox"/>	<input checked="" type="checkbox"/>
1	11.5	R NG 00100 115	<input type="checkbox"/>	<input type="checkbox"/>	<input type="checkbox"/>
1-1/2	11.5	R NG 00112 115	<input type="checkbox"/>	<input type="checkbox"/>	<input type="checkbox"/>

3/4-14 NGT Crest Truncation Ring

 Gauges for Chlorine gas cylinder & oversize valves (CL-2, CL-3, CL-4, CL-5) are in our manufacturing program. **PRICES ON REQUEST**

- other than LPG (TAPER 3 IN 25)

Specification: BS EN ISO 11363

Aplikácia: Ventily kontajnerov používané na prepravu trvalých, skvapalnených a rozpustených plynov až do pracovného tlaku 400 barov. Ventily dýchacích prístrojov, Hasiace prístroje.



panas

Own manufacturing program includes gauges as per BS 341-1963, BS 341-1991, & DIN 477. PRICES ON REQUEST

<input checked="" type="checkbox"/> Na sklade <input type="checkbox"/> Na objednávku								
Size	TPI	Catalogue Code	Single Part Thread Plug	2 Part Thread Plug to check Pitch Dia. at small end	2 Part Thread Plug to check Pitch Dia. at large end	Single Part Plain Plug	2 Part Plain Plug to check Pitch Dia. at small end	2 Part Plain Plug to check Pitch Dia. at large end
			Gauge I-2	Gauge I-4	Gauge I-6	Gauge I-1	Gauge I-3	Gauge I-5
17E	14	P GS 00017 014	✓	✓	✓	✓	✓	✓
25E	14	P GS 00025 014	✓	✓	✓	✓	✓	✓

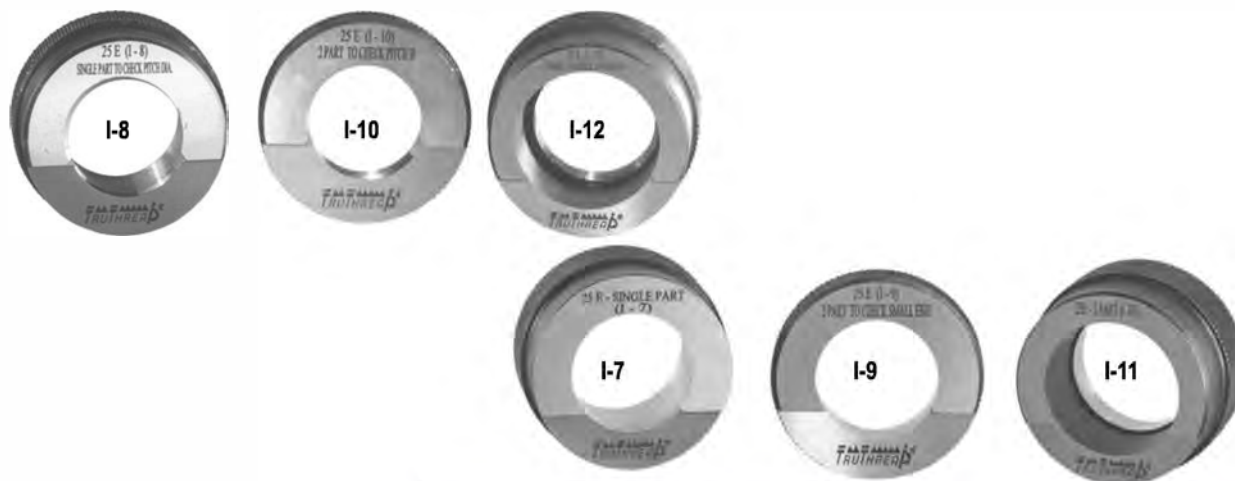

<input checked="" type="checkbox"/> Na sklade <input type="checkbox"/> Na objednávku								
Size	TPI	Catalogue Code	Single Part Thread Ring	2 Part Thread Ring to check Pitch Dia. at small end	2 Part Thread Ring to check Pitch Dia. at large end	Single Part Plain Ring	2 Part Plain Ring to check Pitch Dia. at small end	2 Part Plain Ring to check Pitch Dia. at large end
			Gauge I-8	Gauge I-10	Gauge I-12	Gauge I-7	Gauge I-9	Gauge I-11
17E	14	R GS 00017 014	✓	✓	✓	✓	✓	✓
25E	14	R GS 00025 014	✓	✓	✓	✓	✓	✓